

REV	LOCATIONS	DESCRIPTION	DATE	REVISER	APPD
1	△	Add height series	06/DEC/22	MATT	CHERRY

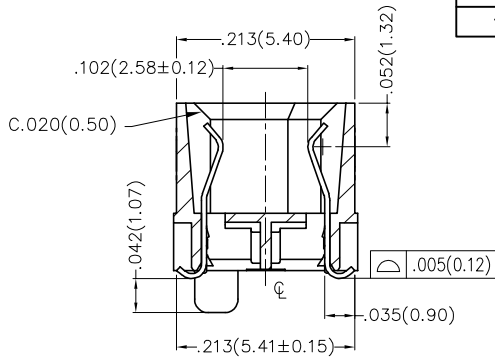
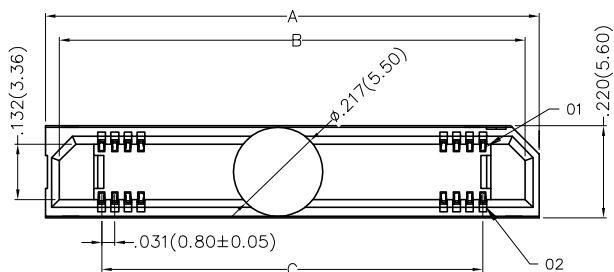

Section A-A
Scale 2:1

SPECIFICATIONS

Electrical
 Current Rating: 0.5A AC(rms)/DC
 Voltage Rating: 50V AC(rms)/DC
 Contact Resistance: 50 mΩ Max.
 Insulation Resistance: 100 MΩ Min.
 Withstanding Voltage: 200V AC r.m.s
 Temperature Range—Operating: -40°C~+85°C

Material and Plating
 Housing: LCP (UL 94V-0)
 Contacts: Phosphor Bronze/ Selective gold in contact area, tin on tail

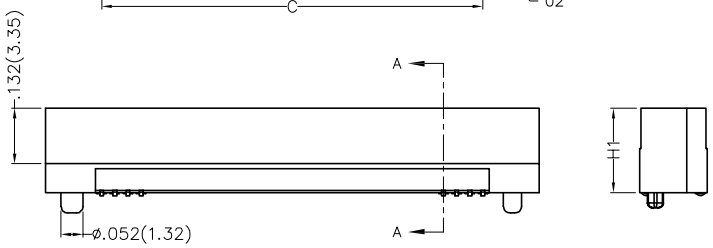

Dimensions(in/mm)				
Mated Height H	Female H1	Male H2	Male H3	Note
.276(7.00)	.118(5.10)	.063(1.61)	.235(5.97)	
.354(9.00)	.276(7.00)	.063(1.61)	.235(5.97)	
.394(10.00)	.118(5.10)	.181(4.61)	.351(8.91)	
.433(11.00)	.354(9.00)	.063(1.61)	.235(5.97)	only 40 50 100 Circuits
.472(12.00)	.276(7.00)	.181(4.61)	.351(8.91)	
.551(14.00)	.354(9.00)	.181(4.61)	.351(8.91)	only 40 50 100 Circuits
.551(14.00)	.118(5.10)	.339(8.61)	.508(12.91)	only 40 Circuits
.630(16.00)	.276(7.00)	.339(8.61)	.508(12.91)	only 40 Circuits
.709(18.00)	.354(9.00)	.339(8.61)	.508(12.91)	only 40 Circuits

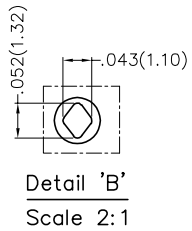
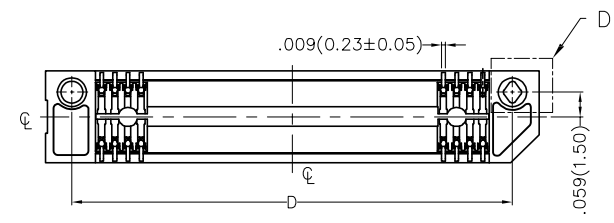

Detail 'B'
Scale 2:1

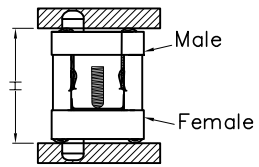

Ordering Information

FBB 080 05 — F XX S 3 XX 3 K6 M HXX
 1 2 3 4 5 6 7 8 9 10 11 12

1 Category FBB—Board to Board	2 Series Number 080—Pitch0.80mm	3 Distinction No. 05	4 Type F—Female	5 Circuits XX	6 Entry Angle S—180° Vertical
7 Plating 3—Selective gold in contact area, tin on tail	8 Thickness of Plating 03—3μ 05—5μ Custom plate available	9 Material—Resin 3—LCP	10 Color—Resin K6—Black	11 Packaging M—Reel	12 Female High △ H50—H1=5.1mm H70—H1=7.0mm H90—H1=9.0mm

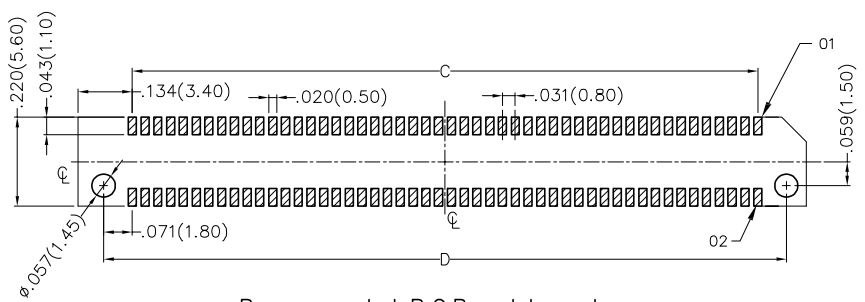

Recommended P.C.Board Layout
 General Tolerances: ±0.05mm

THIRD ANGLE PROJECTION	GENERAL TOLERANCES (UNLESS SPECIFIED)		APPROVE BY FRANK	DATE 21/DEC/18	PART NO. FBB08005—FXXS3XX3K6MHXX	ITEM NO. FBB08005	 Leader Of Industry
	DESIGN UNITS Inch (metric)	X.±.012(0.30) X.X±.008(0.20) X.XX±.006(0.15) X.XXX±.004(0.10)	X.±5° .X'±2° .XX'±1° .XXX'±0.5°	CHECKED BY CHERRY	DATE 21/DEC/18	TITLE Board to Board Pitch 0.8mm 180° Vertical (SMT)	
SCALE 5:1	SIZE A4		DRAWN BY KATE	DATE 21/DEC/18	THIS DRAWING CONTAINS INFORMATION THAT IS PROPRIETARY TO TXGA INDUSTRIAL ELECTRONICS(S.Z)CO.,LTD AND SHOULD NOT BE USED WITHOUT WRITTEN PERMISSION		

1 2 3 4 5 6 7 8

REV	LOCATIONS	DESCRIPTION	DATE	REVISER	APPD

A

B

C

D

E

F

A

B



C

D

E

F

Circuits (n)	Part No.	Dimensions(in./mm)			
		A	B	C	D
20	FBB08005-F20S3XX3K6MHXX	.551(14.00)	.485(12.32)	.283(7.20)	.425(10.80)
30	FBB08005-F30S3XX3K6MHXX	.709(18.00)	.643(16.32)	.441(11.20)	.583(14.80)
40	FBB08005-F40S3XX3K6MHXX	.866(22.00)	.800(20.32)	.598(15.20)	.740(18.80)
50	FBB08005-F50S3XX3K6MHXX	1.024(26.00)	.957(24.32)	.756(19.20)	.898(22.80)
60	FBB08005-F60S3XX3K6MHXX	1.181(30.00)	1.115(28.32)	.913(23.20)	1.055(26.80)
80	FBB08005-F80S3XX3K6MHXX	1.496(38.00)	1.430(36.32)	1.228(31.20)	1.370(34.80)
100	FBB08005-F100S3XX3K6MHXX	1.811(46.00)	1.745(44.32)	1.543(39.20)	1.685(42.80)
120	FBB08005-F120S3XX3K6MHXX	2.126(54.00)	2.060(52.32)	1.858(47.20)	2.000(50.80)
150	FBB08005-F150S3XX3K6MHXX	2.598(66.00)	2.532(64.32)	2.331(59.20)	2.472(62.80)

 THIRD ANGLE PROJECTION	GENERAL TOLERANCES (UNLESS SPECIFIED)		APPROVE BY FRANK	DATE 21/DEC/18	PART NO. FBB08005-FXXS3XX3K6MHXX	ITEM NO. FBB08005	 Leader Of Industry		
	X.±.012(0.30)	X.±5°	CHECKED BY CHERRY	DATE 21/DEC/18	TITLE Board to Board Pitch 0.8mm 180° Vertical (SMT)			REV 1	SHEET NO. 2/2
	DESIGN UNITS Inch (metric)	X.X±.008(0.20)	X.±2°	DRAWN BY KATE	DATE 21/DEC/18	THIS DRAWING CONTAINS INFORMATION THAT IS PROPRIETARY TO TXGA INDUSTRIAL ELECTRONICS(S.Z)CO.,LTD AND SHOULD NOT BE USED WITHOUT WRITTEN PERMISSION			
	SCALE 5:1	SIZE A4	X.XXX±.004(0.10)	.XXX±0.5°					

1 2 3 4 5 6 7 8