

1 2 3 4 5 6 7 8

REV	LOCATIONS	DESCRIPTION	DATE	REVISER	APPD

SPECIFICATION

Electrical  
 Contact Resistance:  
 Center Contact 6mΩ Max.  
 Outer Contact 1mΩ Max.  
 Working Voltage: 335V  
 Insulation Resistance: 1000MΩ  
 Medium Pressure: 1000V  
 Temperature Range: -40 °C~+85 °C  
 Frequency Range: DC-4GHz  
 Impedance: 50Ω

Material and Plating  
 Housing: PTFE (UL 94V-0)  
 Insulator: LCP (UL 94V-0)  
 Contact: Phosphor bronze/Selective gold in contact area  
 Metal shell: Brass  
 Front shell: Nickel plated  
 Black shell: Gold plated  
 Plastic shell: PA66+30%GF

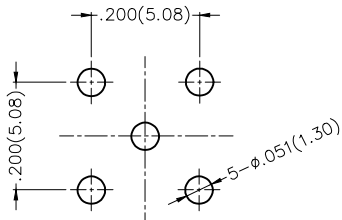
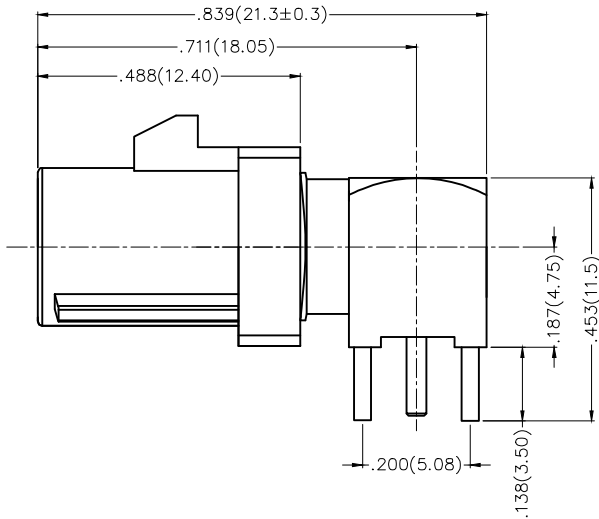
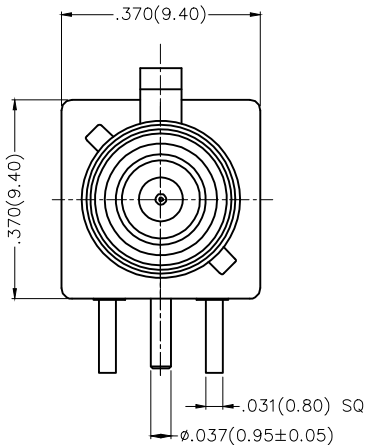

Recommended P.C.Board Layout

Ordering Information

FRF 02 003 - P D B 1 03 K X  
 1 2 3 4 5 6 7 8 9 10

1 Category FRF-Radio Frequency	2 Series Number 02-FAKRA SMB Series	3 Distinction No. 003	4 Type P-Plug	5 Assemble Layout D-DIP
6 Entry Angle B-90° Angle	7 Plating 1-Gold Plated	8 Thickness of Plating 00-Gold Plated 03-3μ"	9 Packaging K-Tray	10 Distinction type A,B... -Serial number (See Table1)

<p>THIRD ANGLE PROJECTION</p>	GENERAL TOLERANCES (UNLESS SPECIFIED)		APPROVE BY FRANK	DATE 08/JUL/16	PART NO. FRF02003-PDB10KXX	ITEM NO. FRF02003	<p>Leader Of Industry</p>
	X.±.012(0.30)	X.'±5'	CHECKED BY CHERRY	DATE 08/JUL/16	TITLE FAKRA SMB Connector 90° Angle Male (DIP)		
DESIGN UNITS Inch (metric)	X.X±.008(0.20)	.X'±2'	DRAWN BY KATE	DATE 08/JUL/16	THIS DRAWING CONTAINS INFORMATION THAT IS PROPRIETARY TO TXGA INDUSTRIAL ELECTRONICS(S.Z)CO.,LTD AND SHOULD NOT BE USED WITHOUT WRITTEN PERMISSION		
SCALE 5:1	SIZE A4	X.XX±.006(0.15)					
		X.XXX±.004(0.10)					

1 2 3 4 5 6 7 8

1 2 3 4 5 6 7 8

REV	LOCATIONS	DESCRIPTION	DATE	REVISER	APPD

Distinction type:

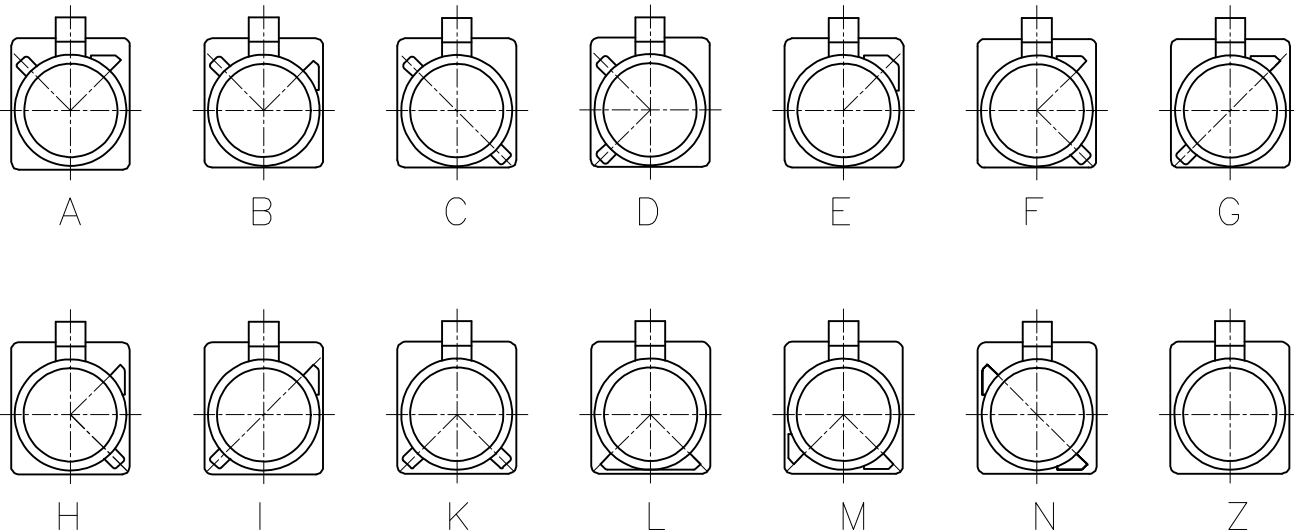

Table1

Type	Part No.	Color
A	FRF02003-PDB1XXKA	Black
B	FRF02003-PDB1XXKB	White
C	FRF02003-PDB1XXKC	Blue
D	FRF02003-PDB1XXKD	Violet
E	FRF02003-PDB1XXKE	Green
F	FRF02003-PDB1XXKF	Brown
G	FRF02003-PDB1XXKG	Gray
H	FRF02003-PDB1XXKH	Pink
I	FRF02003-PDB1XXKI	Beige
K	FRF02003-PDB1XXKK	Curry
L	FRF02003-PDB1XXKL	Red
M	FRF02003-PDB1XXKM	Orange
N	FRF02003-PDB1XXKN	Pastel Green
Z	FRF02003-PDB1XXKZ	Water Blue

<p>THIRD ANGLE PROJECTION</p>	GENERAL TOLERANCES (UNLESS SPECIFIED)		APPROVE BY FRANK	DATE 08/JUL/16	PART NO. FRF02003-PDB1XXKX	ITEM NO. FRF02003	<p>Leader Of Industry</p>	
	DESIGN UNITS Inch (metric)	X.±.012(0.30) X.X±.008(0.20) X.XX±.006(0.15) X.XXX±.004(0.10)	X.±5° .X'±2° .XX'±1° .XXX'±0.5'	CHECKED BY CHERRY	DATE 08/JUL/16	TITLE FAKRA SMB Connector 90° Angle Male (DIP)		
	SCALE 5:1	SIZE A4	DRAWN BY KATE	DATE 08/JUL/16	THIS DRAWING CONTAINS INFORMATION THAT IS PROPRIETARY TO TXGA INDUSTRIAL ELECTRONICS(S.Z)CO.,LTD AND SHOULD NOT BE USED WITHOUT WRITTEN PERMISSION			

1 2 3 4 5 6 7 8