

REV	LOCATIONS	DESCRIPTION	DATE	REVISER	APPD
1	△	Size changes	10/JUN/22	MATT	CHERRY

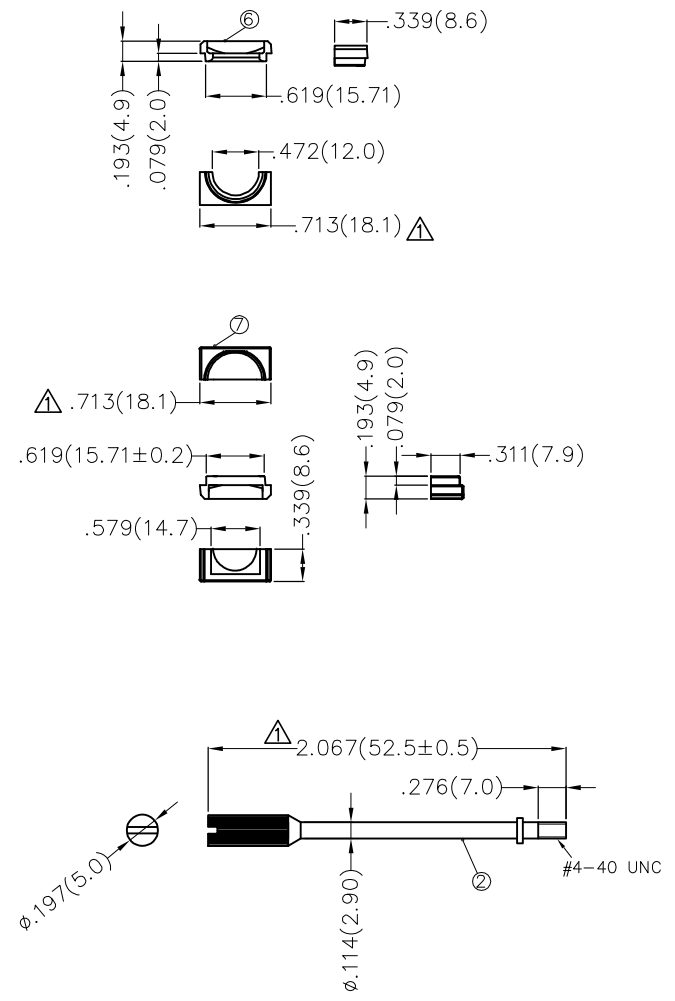
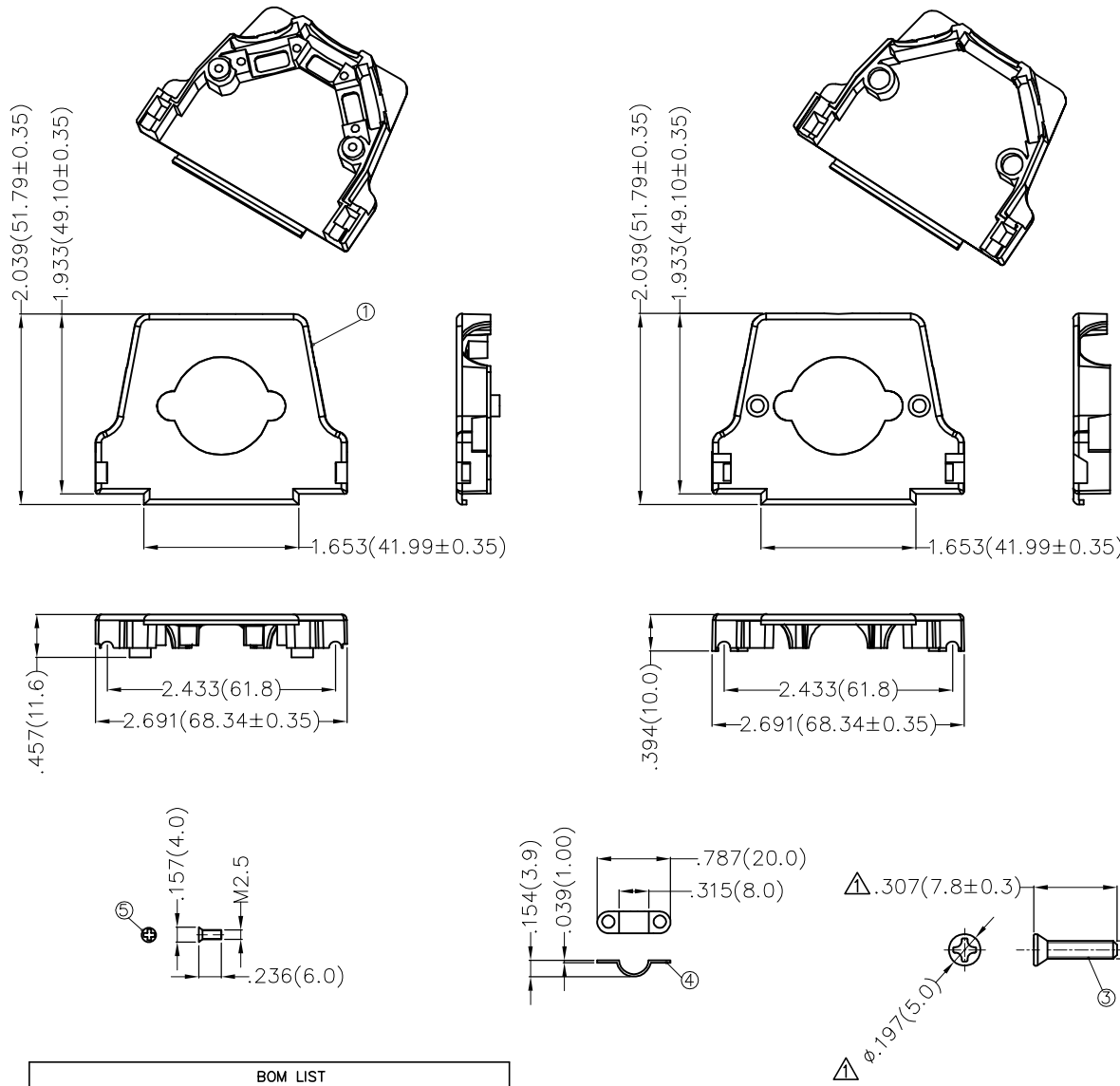

BOM LIST			
Item	Part name	Q'ty	Notes
①	Metal hood	2	Zinc alloy/ Ni plated
②	Long screw	2	#4-40 UNC, Steel/ Ni plated
③	Screw for hood	2	M3.0, Steel/ Ni plated
④	Cable clamp	1	Zinc alloy/ Ni plated
⑤	Screw for clamp	2	M2.5, Steel/ Ni plated
⑥	Cable holder	2	Zinc alloy/ Ni plated
⑦	Strain relief	4	Zinc alloy/ Ni plated

 THIRD ANGLE PROJECTION	GENERAL TOLERANCES (UNLESS SPECIFIED)		APPROVE BY FRANK	DATE 14/OCT/19	PART NO. FDB5001-C200B	ITEM NO. FDB5001-C	 Leader Of Industry
	DESIGN UNITS Inch (metric)	X.±.012(0.30)	X'.±5'	CHECKED BY CHERRY	DATE 14/OCT/19	TITLE D-SUB Connectors 50 Circuits Cover	
SCALE 5:1	SIZE A4	X.XX±.008(0.20)	.XX'±2'	DRAWN BY KATE	DATE 14/OCT/19	THIS DRAWING CONTAINS INFORMATION THAT IS PROPRIETARY TO TXGA INDUSTRIAL ELECTRONICS(S.Z)CO.,LTD AND SHOULD NOT BE USED WITHOUT WRITTEN PERMISSION	
		X.XXX±.004(0.10)	.XXX'±0.5'			REV 1	SHEET NO. 1/1