

REV	LOCATIONS	DESCRIPTION	DATE	REVISER	APPD

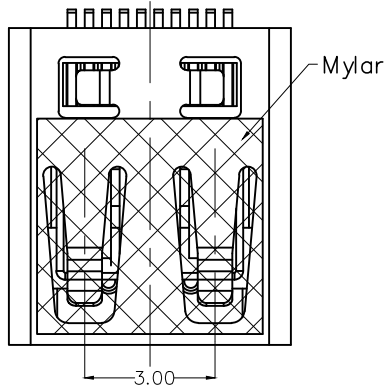

SPECIFICATIONS

Electrical

Current Rating: 0.5A AC(rms)/DC
Voltage Rating: 40V AC(rms)/DC
Contact Resistance: 30 mΩ Max
Insulation Resistance: 100 MΩ Min
Withstanding Voltage: 250V AC r.m.s

Mechanical

Mating force: 4.5KG.F Max
Retention force: 0.5–2.5KG.F
Durability: 5000 cycles Min.

Environmental

Operating Temperature: -25°C~+85°C

Material and plating

Housing: LCP (UL 94V-0), Black
Contacts: Copper Alloy/Gold plated over Ni
Shell: SUS304-1/2H/Nikel plated

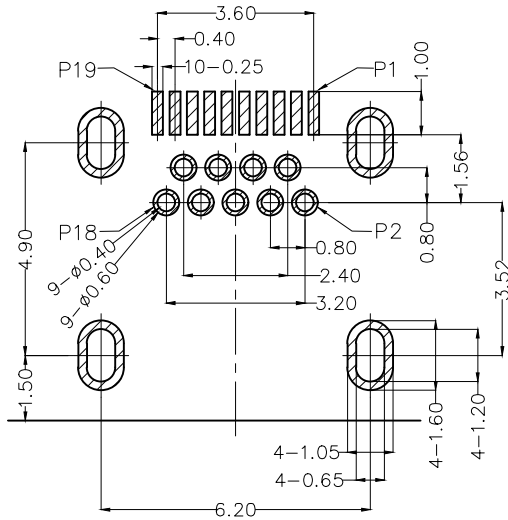
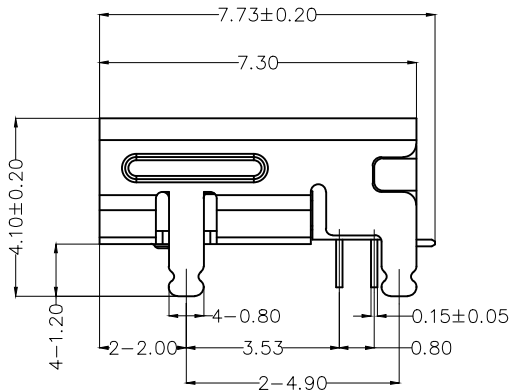
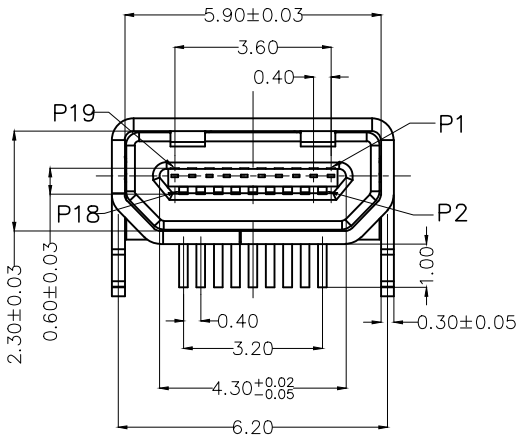

Recommended P.C.Board Layout
General Tolerances: ±0.05mm

Pin	Signal Assignment	Pin	Signal Assignment
1	Hot Plug Detect	11	TMDS Data0-
2	Utility	12	TMDS Clock+
3	TMDS Data2+	13	TMDS Clock Shield
4	TMDS Data2 Shield	14	TMDS Clock-
5	TMDS Data2-	15	CEC
6	TMDS Data1+	16	DDC/CEG Ground
7	TMDS Data1 Shield	17	SCL
8	TMDS Data1-	18	SDA
9	TMDS Data0+	19	+5V Power
10	TMDS Data0 Shield	/	/

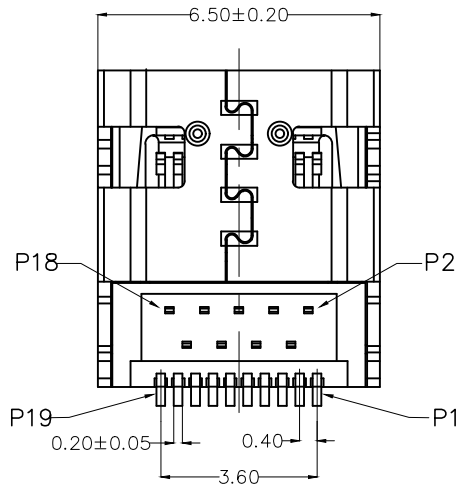

 THIRD ANGLE PROJECTION	GENERAL TOLERANCES (UNLESS SPECIFIED)		APPROVE BY FRANK	DATE 22/AUG/22	PART NO. FHC03-FSB100BKM	ITEM NO. FHC03	 Leader Of Industry
	X.±0.30	X.*±5°	CHECKED BY CHERRY	DATE 22/AUG/22	TITLE HDMI D/F 90°(Hybird solder)		
	X.XX±0.15	.XX*±1°	DRAWN BY QING	DATE 22/AUG/22	REV 0	SHEET NO. 1/2	
	X.XXX±0.10	.XXX*±0.5°	THIS DRAWING CONTAINS INFORMATION THAT IS PROPRIETARY TO TXGA INDUSTRIAL ELECTRONICS(S.Z)CO.,LTD AND SHOULD NOT BE USED WITHOUT WRITTEN PERMISSION				
DESIGN UNITS Metric							
SCALE 5:1	SIZE A4						

REV	LOCATIONS	DESCRIPTION	DATE	REVISER	APPD

A
B
C
D
E
F

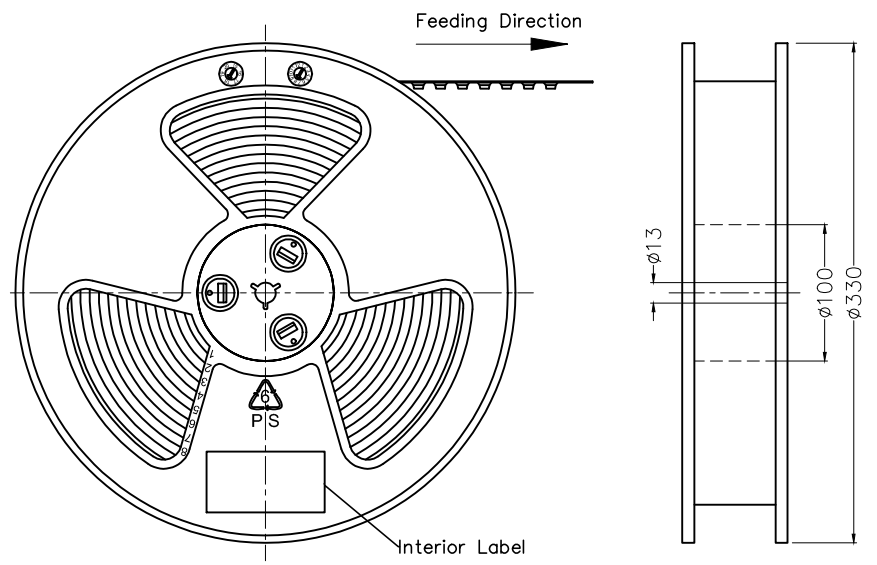

- Note:
- 1.10 sprocket hole cumulative tolerance ± 0.2
 2. Carrier camber is within 1.0mm in 250mm
 3. Material: Clear conductive polystyrene Alloy 100% recyclable
 4. All dimensions meet EIA-481-3 requirements
 5. Peel off force of cover tape & carrier tape: 20g~130g (0.2N~1.3N)
 6. Component load per 13" reel: 1000 pcs

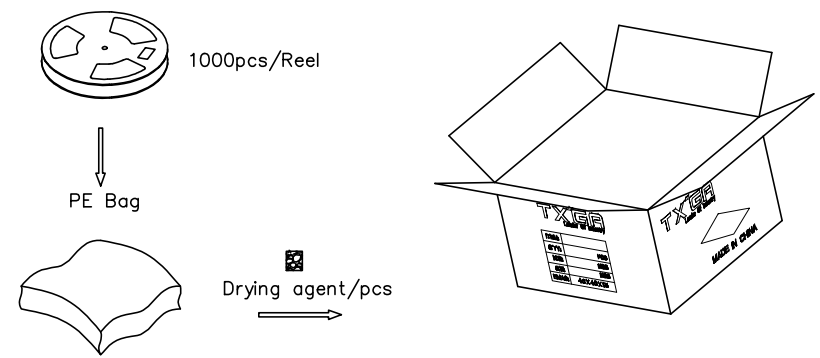
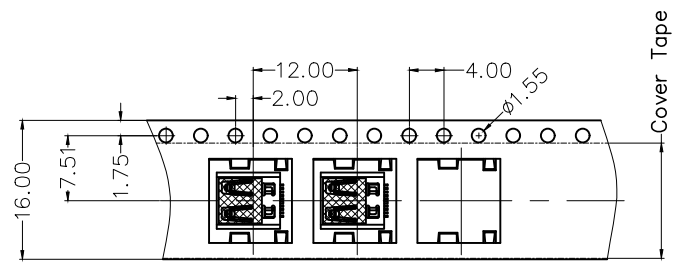
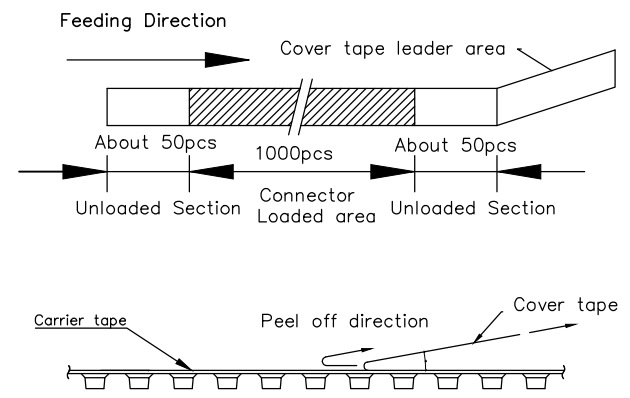

 THIRD ANGLE PROJECTION	GENERAL TOLERANCES (UNLESS SPECIFIED)		APPROVE BY FRANK	DATE 22/AUG/22	PART NO. FHC03-FSB100BKM	ITEM NO. FHC03	 Leader Of Industry
	DESIGN UNITS Metric	X.±0.30	X.±5°	CHECKED BY CHERRY	DATE 22/AUG/22	TITLE HDMI D/F 90°(Hybird solder)	
SCALE 5:1	SIZE A4	X.XX±0.15	.XX'±1°	DRAWN BY QING	DATE 22/AUG/22	THIS DRAWING CONTAINS INFORMATION THAT IS PROPRIETARY TO TXGA INDUSTRIAL ELECTRONICS(S.Z)CO.,LTD AND SHOULD NOT BE USED WITHOUT WRITTEN PERMISSION	
		X.XXX±0.10	.XXX'±0.5°			REV 0	SHEET NO. 2/2