

1 2 3 4 5 6 7 8

REV	LOCATIONS	DESCRIPTION	DATE	REVISER	APPD
1	△	Size changes	24/MAY/21	KATE	CHERRY
2	△	Add applicable panel specification	29/JUN/22	KATE	CHERRY

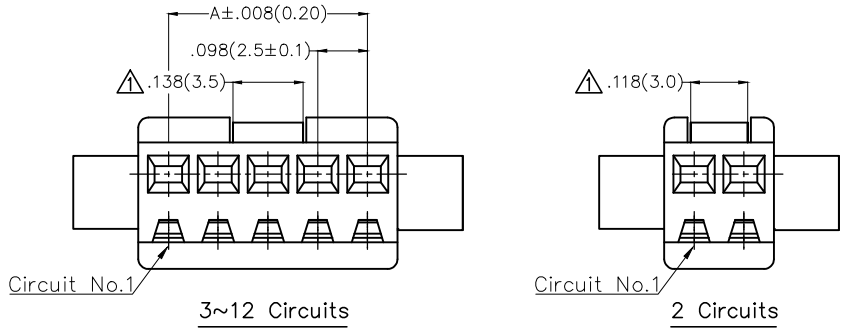

Electrical  
 Temperature Range—Operating: -25°C~+85°C  
 Material  
 Housing: PA66 (UL 94V-0)  
 Applicable Terminal: FT25009  
 Mates With(Housing): FHG25011 Series

Circuits (n)	Part No.	Dimensions(in/mm)	
		A	B
2	FHG25010-S02M2K6B	.098(2.50)	.217(5.50)
3	FHG25010-S03M2K6B	.197(5.00)	.315(8.00)
4	FHG25010-S04M2K6B	.295(7.50)	.413(10.50)
5	FHG25010-S05M2K6B	.394(10.00)	.512(13.00)
6	FHG25010-S06M2K6B	.492(12.50)	.610(15.50)
7	FHG25010-S07M2K6B	.591(15.00)	.709(18.00)
8	FHG25010-S08M2K6B	.689(17.50)	.807(20.50)
9	FHG25010-S09M2K6B	.787(20.00)	.906(23.00)
10	FHG25010-S10M2K6B	.886(22.50)	1.004(25.50)
12	FHG25010-S12M2K6B	1.083(27.50)	1.201(30.50)

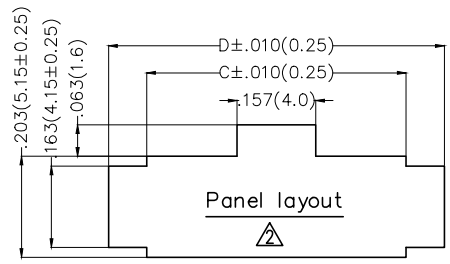
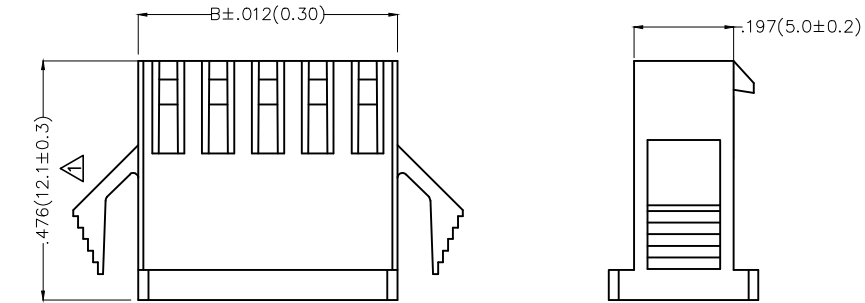

Ordering Information

FHG 250 10 - S XX M 2 K6 B  
 1 2 3 4 5 6 7 8 9

1	Category FHG-Housing	2	Series Number 250-Pitch 2.50mm	3	Distinction No. 10	4	Row Option S-Single row		
5	Circuits XX	6	Type M-Male	7	Material-Resin 2-PA66	8	Color-Resin K6-Black	9	Packaging B-PE Bag

Circuits (n)	Applicable panel thickness (in/mm)			
	C	.020~.035 (0.5~0.9)	.039~.059 (1.0~1.5)	.063~.079 (1.6~2.0)
2	.224(5.7)	.378(9.6)	.386(9.8)	.394(10.0)
3	.323(8.2)	.476(12.1)	.484(12.3)	.492(12.5)
4	.421(10.7)	.575(14.6)	.583(14.8)	.591(15.0)
5	.520(13.2)	.673(17.1)	.681(17.3)	.689(17.5)
6	.618(15.7)	.772(19.6)	.780(19.8)	.787(20.0)
7	.717(18.2)	.870(22.1)	.878(22.3)	.886(22.5)
8	.815(20.7)	.969(24.6)	.976(24.8)	.984(25.0)
9	.913(23.2)	1.067(27.1)	1.075(27.3)	1.083(27.5)
10	1.012(25.7)	1.165(29.6)	1.173(29.8)	1.181(30.0)
12	1.209(30.7)	1.632(34.6)	1.370(34.8)	1.378(35.0)

THIRD ANGLE PROJECTION	GENERAL TOLERANCES (UNLESS SPECIFIED)		APPROVE BY FRANK	DATE 25/JUL/13	PART NO. FHG25010-SXXM2K6B	ITEM NO. FHG25010	 Leader Of Industry	
	DESIGN UNITS Inch (metric)	X.±.012(0.30)	X.±5'	CHECKED BY JACOB	DATE 25/JUL/13	TITLE Wire to Wire Pitch 2.50mm(Housing)		REV 2
SCALE 5:1		SIZE A4	X.XX±.006(0.15)	.XX'±1'	DRAWN BY CHERRY	DATE 25/JUL/13	THIS DRAWING CONTAINS INFORMATION THAT IS PROPRIETARY TO TXGA INDUSTRIAL ELECTRONICS(S.Z)CO.,LTD AND SHOULD NOT BE USED WITHOUT WRITTEN PERMISSION	

1 2 3 4 5 6 7 8