

1	2	3	4	5	6	7	8			
Circuits	3Circuits	4Circuits			REV	LOCATIONS	DESCRIPTION	DATE	REVISER	APPD
A-Coded					0		New Release	4/DEC	LAM	FRANK

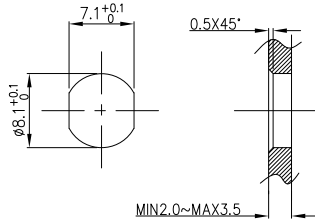

Note:
 1. Ⓞ Important Dimension
 2. Waterproof Rate: IP68
 3. This product must meet IEC61076-2-104
 4. This product must meet 2011/65/EU ROHS compliance.
 5. Not note tolerances: ±0.20
 6. Use torque values 1Nm

Recommended Panel Cut-Out

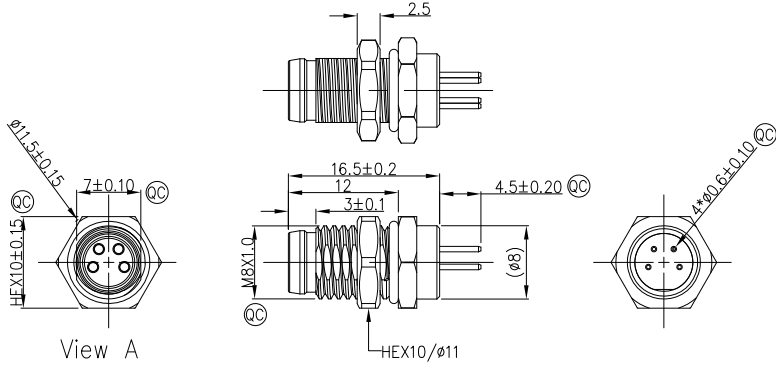

PCB Layout 【Front view A】

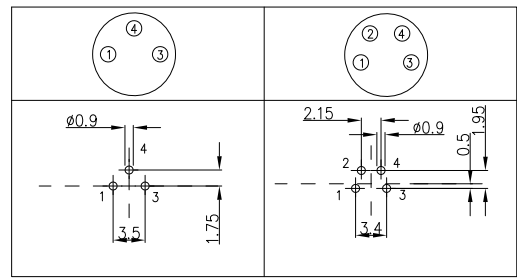

Connector locking system	Screw
Wiring type	Through Hole
Degree of protection	IP68(in mated condition)
Mechanical operation	> 100 mating cycles
Upper temperature	105°C
Lower temperature	-40°C
Pollution degree	3
Overvoltage categorie	II
Material group	II
Material of contact	CuZn (Messing/brass)
Contact plating	Au
Material of contact body	PA
Sealing	EPDM
Material of housing	Brass nickel plated

Ordering Information

FM8S T04 28 - X XX P 1 04 D 00
 1 2 3 4 5 6 7 8 9

1 Series Name - 2 Mounting thread 3 Distinction No. - 4 Coded 5 Circuits 6 Contact
 FM8S-M8 Socket T04-front fastened M8X1.0 28 A-A CODED 03-3Circuits 04-4Circuits P-Plug

7 Plating 8 Thickness Plating 9 Wire type
 1-Ep Au 04-0.1μm D-Through Hole

 THIRD ANGLE PROJECTION DESIGN UNITS Metric SCALE 2:1 SIZE A4	GENERAL TOLERANCES (UNLESS SPECIFIED)		APPROVE BY	DATE	PART NO.		ITEM NO.	 Building Technology Cornerstone REV 0 SHEET NO. 1/1 THIS DRAWING CONTAINS INFORMATION THAT IS PROPRIETARY TO TXGA INDUSTRIAL ELECTRONICS(S,Z)CO.,LTD AND SHOULD NOT BE USED WITHOUT WRITTEN PERMISSION
	X.±0.30	X.±5°	FRANK	4/DEC/23	FM8ST0428-XXXP104D00		FM8ST0428	
	X.X±0.20	.X'±2°	CHECKED BY	DATE	TITLE			
	X.XX±0.15	.XX'±1°	CHERRY	4/DEC/23	M8X1.0 male socket front fastened M8X1.0 180° THT [metal double section]			
X.XXX±0.10	.XXX'±0.5°	DRAWN BY	DATE					
		LAM	4/DEC/23					