

REV	LOCATIONS	DESCRIPTION	DATE	REVISER	APPD
			2025-01-08		HUANG

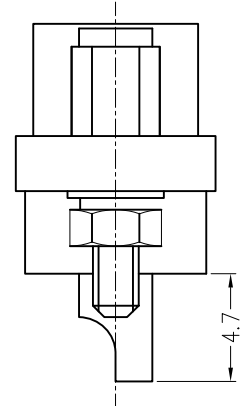
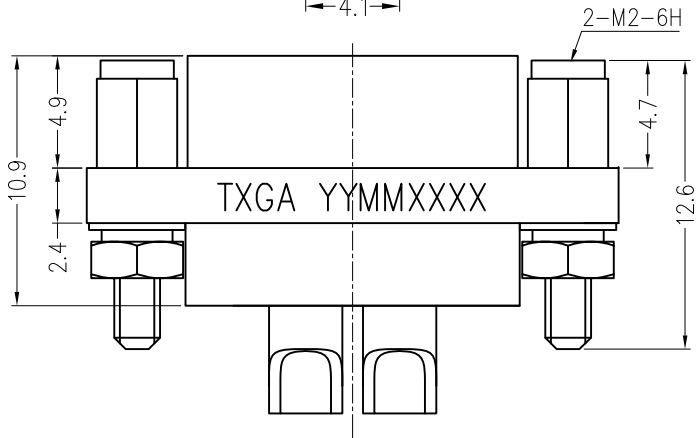
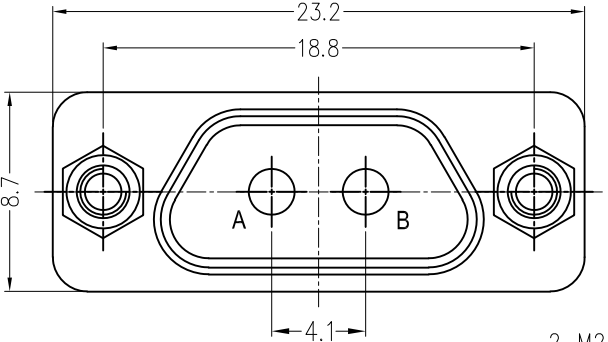
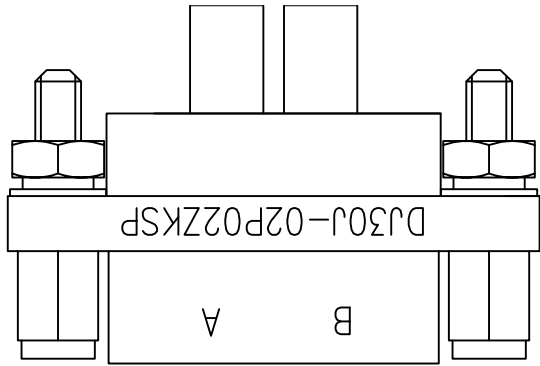

Electrical
 Current Rating: 20A
 Voltage Rating: 500V AC(rms)
 Contact Resistance: 10mΩ (MAX)
 Insulation Resistance: 5000MΩ (MIN)
 Withstanding Voltage: 800V AC r.m.s
 Temperature Range-Operating: -55°C~+125°C

Mechanical
 Durability: 500 Cycles
 Vibration: Frequency 10~2000Hz, Acceleration 196m/s²,
 Shock: Peak Acceleration 735m/s².

Material and Plating
 Housing: High-temperature plastic (UL94V-0)
 Shell: Aluminum alloy /plated Nickel
 Contact Pin: Copper alloy /plated Gold
 Nut: Stainless steel
 Wire Range: AFR250 2.0~3.0mm².

Ordering Information

FMDP 02 - F 002 S W BK - S 0
 1 2 3 4 5 6 7 8

1 Category FMDP-Micro-D Connector Mixed power	2 Distinction No. 02	3 Gender F-Female	4 Circuits 2
5 Entry Angle S-180° Vertical	6 Assembly Layout W-Soldering	7 Color-Resin BK-Black	8 Type S-Standard

 THIRD ANGLE PROJECTION DESIGN UNITS METRIC(mm) SCALE NTS SIZE A4	GENERAL TOLERANCES (UNLESS SPECIFIED)		APPROVE BY LEO	DATE 19/MAY/25	PART NO. FMDP02-F002SWBK-S0	ITEM NO. FMDP02	 Building Technology Cornerstone
	X. ±0.30	X.' ±5'	CHECKED BY GISELLE	DATE 19/MAY/25	TITLE Micro-D Connector Mixed power 2P2 Female Soldering		
	X.XX ±0.20	X.X' ±2'	DRAWN BY HUANG	DATE 19/MAY/25	THIS DRAWING CONTAINS INFORMATION THAT IS PROPRIETARY TO TXGA INDUSTRIAL ELECTRONICS(S.Z)CO.,LTD AND SHOULD NOT BE USED WITHOUT WRITTEN PERMISSION		
	X.XX ±0.15	X.XX' ±1'					
X.XXX ±0.10	X.XXX' ±0.5'						