

REV	LOCATIONS	DESCRIPTION	DATE	REVISER	APPD
0		New Release	4/JUNE		FRANK

Material
connector parts material Plating
inner contact bronze Gold
outer contact brass Sn
housing LCP
Flame proofing
Component category
overmold material conforms to UL94V-0
housing material conforms to UL94V-0
RoHS compliant
Standards According to the standard IEC 61076-3-122

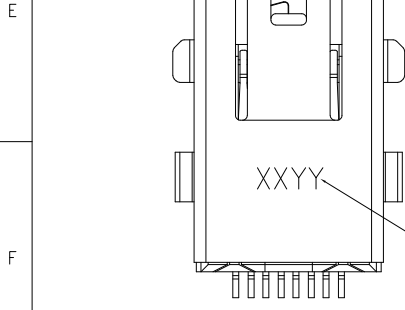
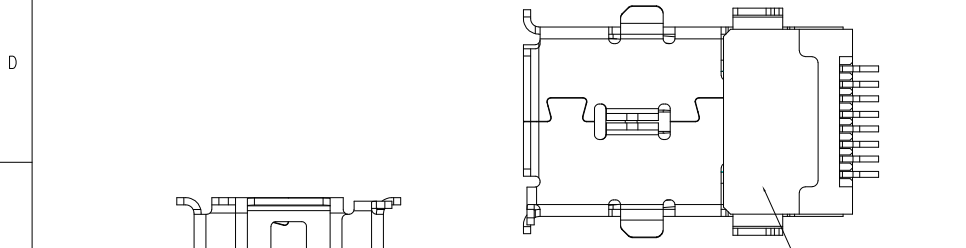
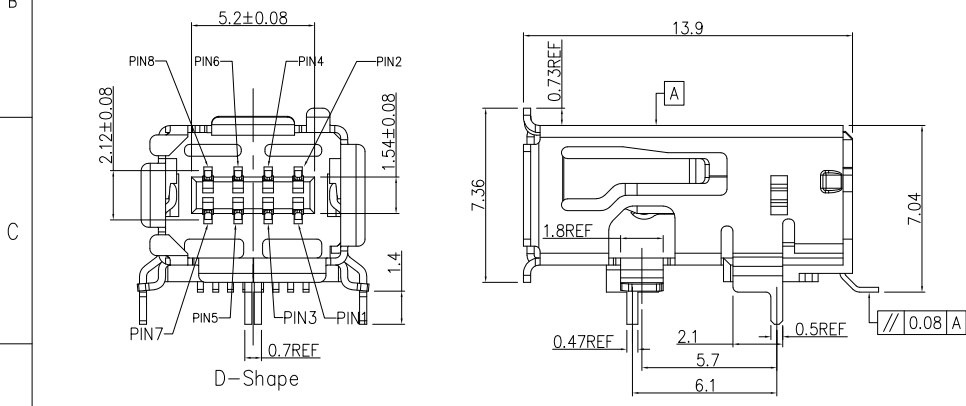
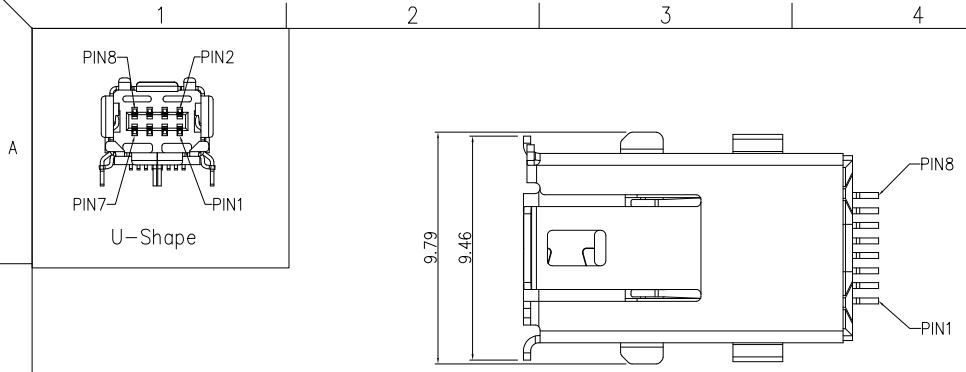
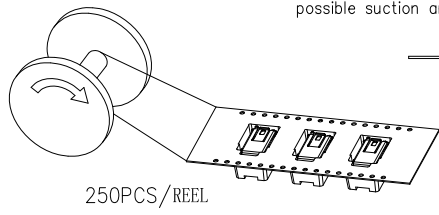
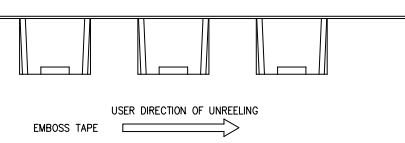
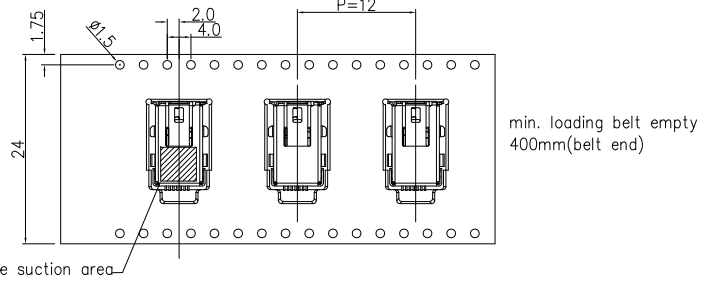
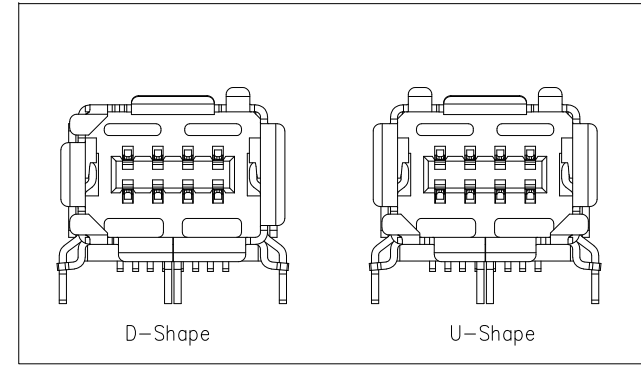

生产Lot No. 【年+周数】 喷码标识
XX-- 公历年后两位, 如2024取24
YY-- 周数, 如25代表第25周生产

 THIRD ANGLE PROJECTION DESIGN UNITS Metric SCALE 4:1 SIZE A4	GENERAL TOLERANCES (UNLESS SPECIFIED)		DATE	APPROVE BY	PART NO.	ITEM NO.	 Building Technology Cornerstone REV 0 SHEET NO. 1/2 THIS DRAWING CONTAINS INFORMATION THAT IS PROPRIETARY TO TXGA INDUSTRIAL ELECTRONICS(S.Z)CO.,LTD AND SHOULD NOT BE USED WITHOUT WRITTEN PERMISSION
	X.±0.12(0.30)	X.±5'	FRANK	4/JUNE/24	FMINI-SXRAX1XX-000	FMINI	
	X.X±.008(0.20)	.X'±2'	CHECKED BY	DATE	TITLE		
	X.XX±.006(0.15)	.XX±1'	CHERRY	4/JUNE/24	MINI 1/0 D/U Shape Socket RA SMT		
	X.XXX±.004(0.10)	.XXX±0.5'	DRAWN BY	DATE			
			DANIEL	4/JUNE/24			

REV	LOCATIONS	DESCRIPTION	DATE	REVISER	APPD
0		New Release	4/JUNE		FRANK

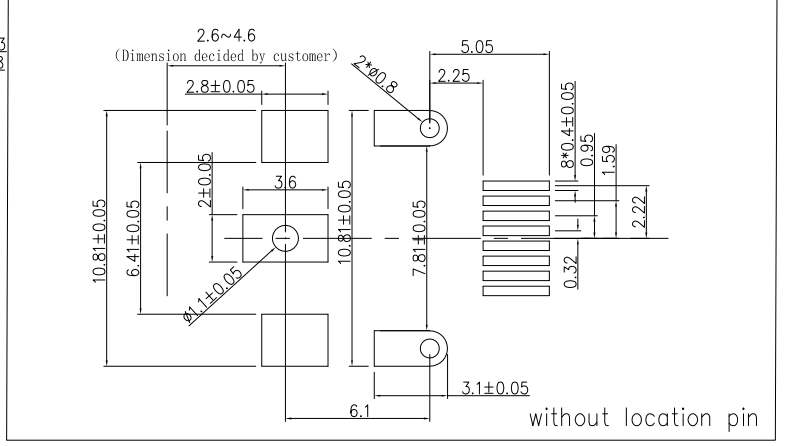
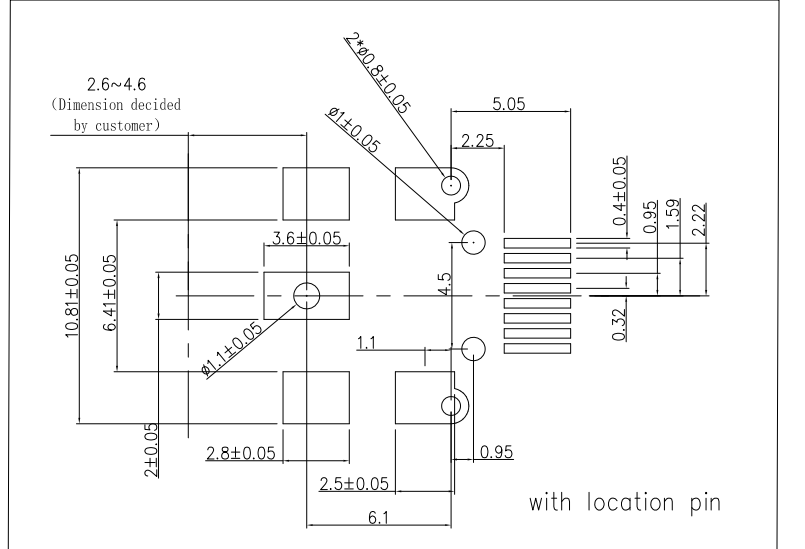
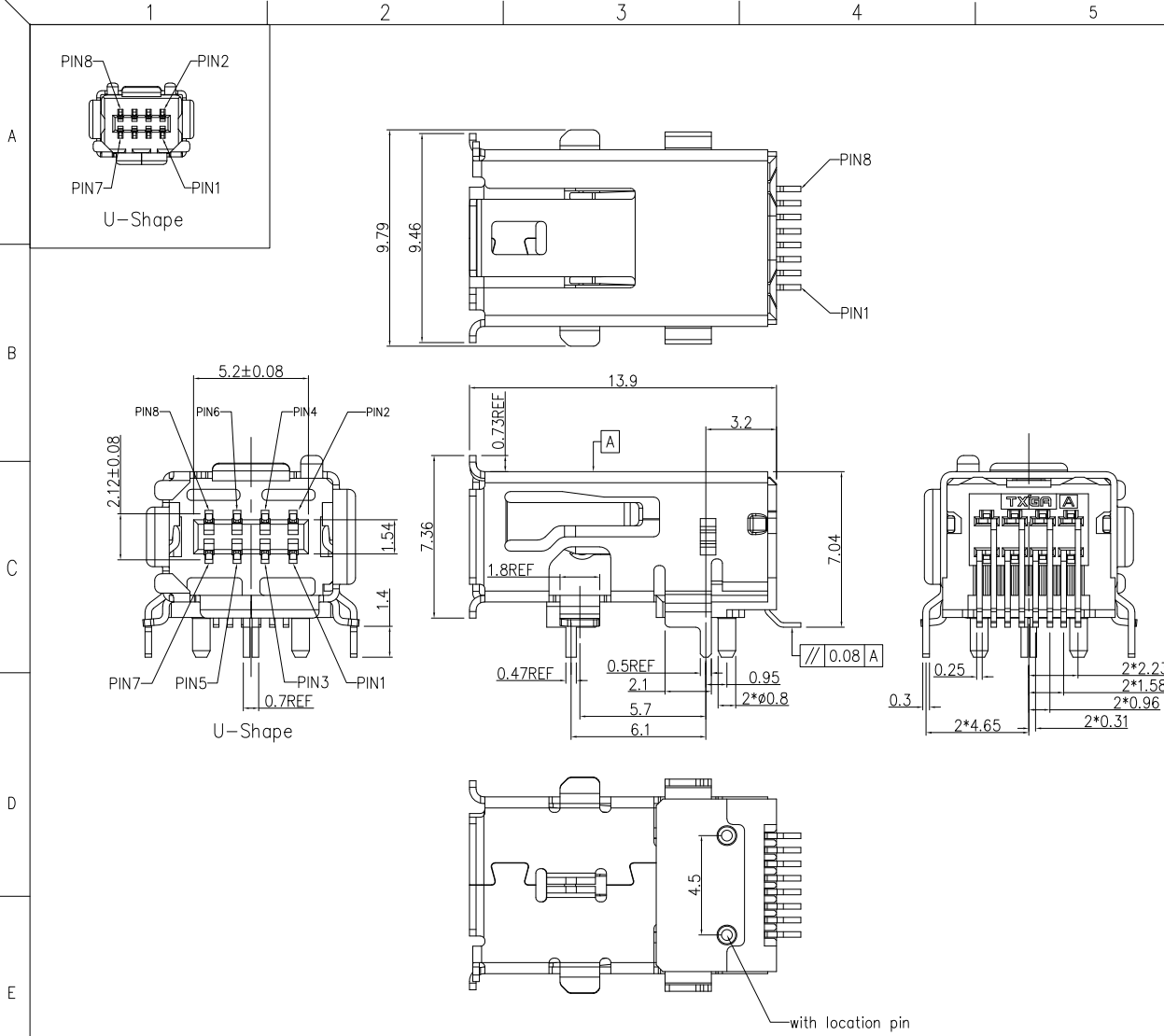

REFERENCE PCB DIMENSIONS

Ordering Information

1	Series Name	2	Type	3	Type	4	Entry Angle	5	housing
1	FMINI	2	S- Socket	3	D- D shape U- U shape	4	RA- Right angle	5	0- without location pin 1- with location pin
6	Contact	7	thickness of Plating	8	Serial Number				
6	1- EP AU	7	15-15u" 20-20u"	8	000				

<p>THIRD ANGLE PROJECTION</p>	GENERAL TOLERANCES (UNLESS SPECIFIED)		DATE	APPROVE BY	PART NO.	ITEM NO.	<p>Building Technology Cornerstone</p>	
	X.±0.12(0.30)	X.±5°	FRANK	4/JUNE/24	FMINI-SXRAX1XX-000	FMINI		
	DESIGN UNITS Metric		CHECKED BY	DATE	TITLE			
	X.X±.008(0.20)	.X'±2°	CHERRY	4/JUNE/24	MINI 1/0 D/U Shape Socket RA SMT			
SCALE	SIZE	X.XX±.006(0.15)	.XX'±1°	DRAWN BY	DATE	THIS DRAWING CONTAINS INFORMATION THAT IS PROPRIETARY TO TXGA INDUSTRIAL ELECTRONICS(S.Z)CO.,LTD AND SHOULD NOT BE USED WITHOUT WRITTEN PERMISSION		
4:1	A4	X.XXX±.004(0.10)	.XXX'±0.5°	DANIEL	4/JUNE/24	REV 0	SHEET NO. 2/2	