

REV	LOCATIONS	DESCRIPTION	DATE	REVISER	APPD
0		New Release	4/JUNE	LAM	FRANK

Material
connector parts material Plating
inner contact bronze Gold
outer contact brass Sn
housing LCP
Flame proofing
Component category
overmold material conforms to UL94V-0
housing material conforms to UL94V-0
RoHS compliant
Standards
According the standard IEC 61076-3-122

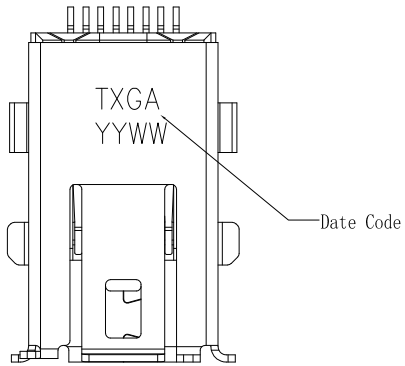
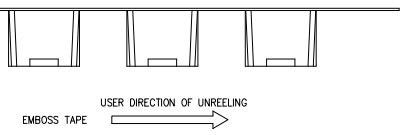
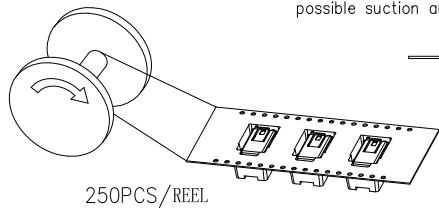
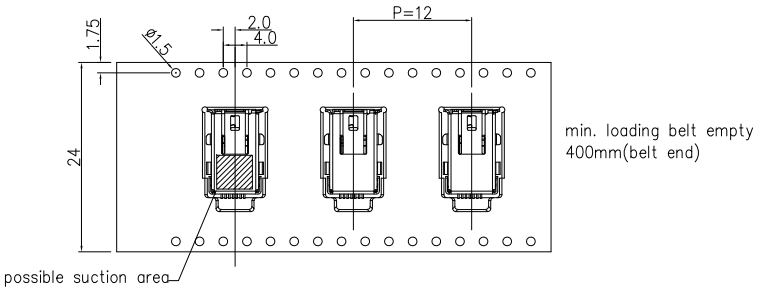
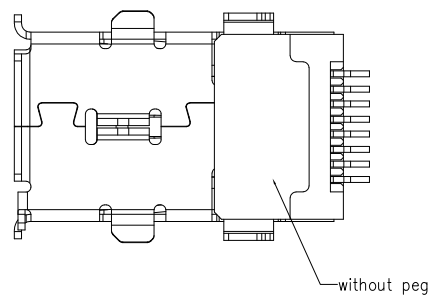
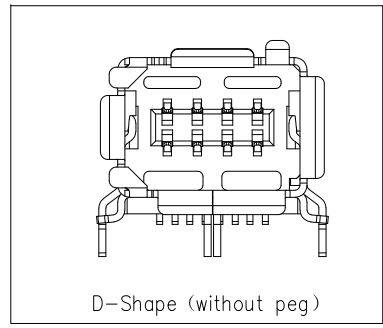
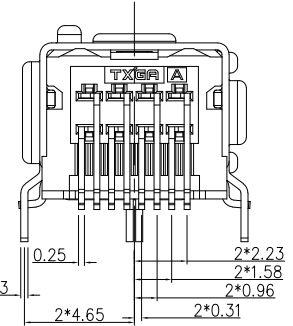
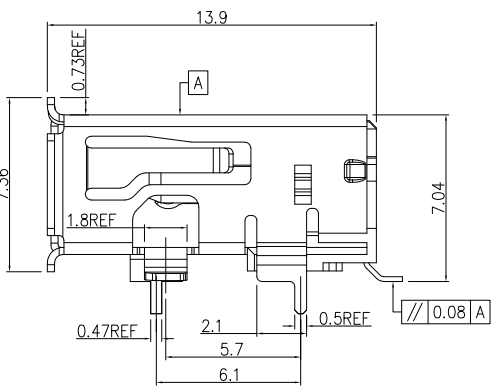
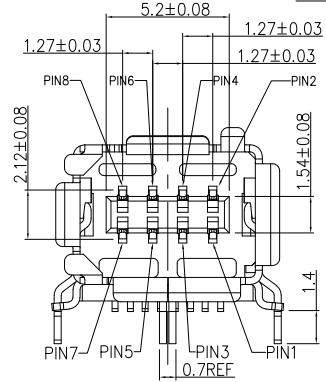
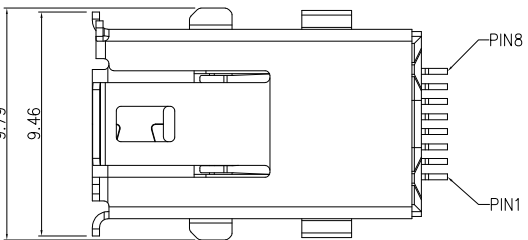

 THIRD ANGLE PROJECTION	GENERAL TOLERANCES (UNLESS SPECIFIED)		DATE FRANK	APPROVE BY 4/JUNE/24	PART NO. FMNTD03-F08BS716NM00	ITEM NO. FMNTD03	 Building Technology Cornerstone	
	X.±0.30	.X'±5'	CHECKED BY CHERRY	DATE 4/JUNE/24	TITLE MINI I/O D Shape Socket RA SMT(without peg)			REV 0
	DESIGN UNITS Metric	X.XX±0.20	.X'±2'	DRAWN BY LAM	DATE 4/JUNE/24	THIS DRAWING CONTAINS INFORMATION THAT IS PROPRIETARY TO TXGA INDUSTRIAL ELECTRONICS(S,Z)CO.,LTD AND SHOULD NOT BE USED WITHOUT WRITTEN PERMISSION		SHEET NO. 1/2
	SCALE 4:1	SIZE A4	X.XX±0.15	.XX'±1'				
		X.XXX±0.10	.XXX'±0.5'					

REV	LOCATIONS	DESCRIPTION	DATE	REVISER	APPD
0		New Release	4/JUNE	LAM	FRANK

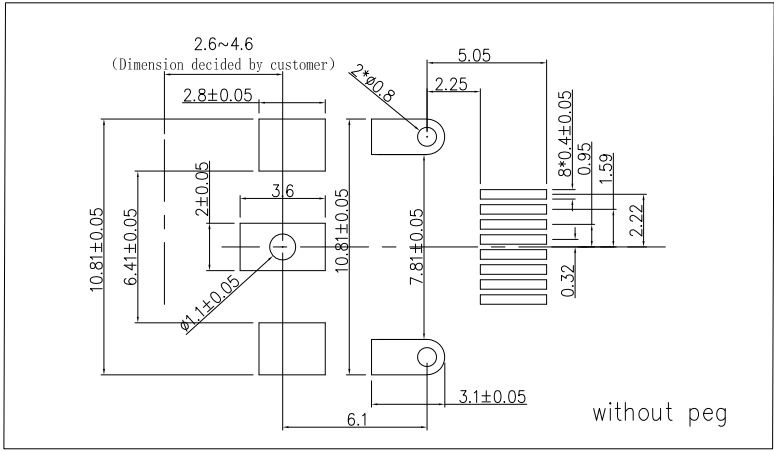

REFERENCE PCB DIMENSIONS

Ordering Information

FMNTD03 - F 08 B S 7 16 N M 00
 1 2 3 4 5 6 7 8 9

1 Series Name - 2 Gender 3 Circuits 4 Orientation 5 Mounting Style
 FMNTD03 F-Female 08-8Circuits B-Right angle(90°) S-SMT

6 Contact plating 7 Contact plating thickness 8 Peg 9 Packaging
 7-Gold on contact,matte tin on tail 16-0.5μm N-Without peg M-Reel

 THIRD ANGLE PROJECTION	GENERAL TOLERANCES (UNLESS SPECIFIED)		DATE	APPROVE BY	PART NO.	ITEM NO.	 Building Technology Cornerstone
	X.±0.30	.X'±5'	FRANK	4/JUNE/24	FMNTD03-F08BS716NM00	FMNTD03	
	DESIGN UNITS Metric		CHECKED BY	DATE	TITLE		REV 0 SHEET NO. 2/2 THIS DRAWING CONTAINS INFORMATION THAT IS PROPRIETARY TO TXGA INDUSTRIAL ELECTRONICS(S.Z)CO.,LTD AND SHOULD NOT BE USED WITHOUT WRITTEN PERMISSION
	X.X±0.20	.X'±2'	CHERRY	4/JUNE/24	MINI I/O D Shape Socket RA SMT(without peg)		
SCALE 4:1	SIZE A4	X.XX±0.15	.XX'±1'	DRAWN BY LAM	DATE 4/JUNE/24		
		X.XXX±0.10	.XXX'±0.5'				