

1 2 3 4 5 6 7 8

REV	LOCATIONS	DESCRIPTION	DATE	REVISER	APPD

- Notes:
- Material:
    - Machined Terminal: Brass
    - Crown Spring: Beryllium Copper
  - Plating:
    - Machined Terminal: 50µ" Silver Plated, 80~100µ" Nickel Under Plated Over All.
    - Crown Spring: 5µ" Gold Plated, 100~120µ" Nickel Under Plated Over All.
  - Applicable Terminal:  $\phi 3.00\text{mm}$
  - Curing test
  - All Materials Meet The "RoHs"
  - 1000 pcs/Bag

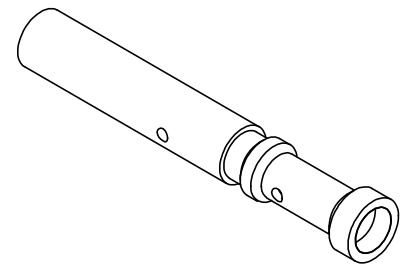
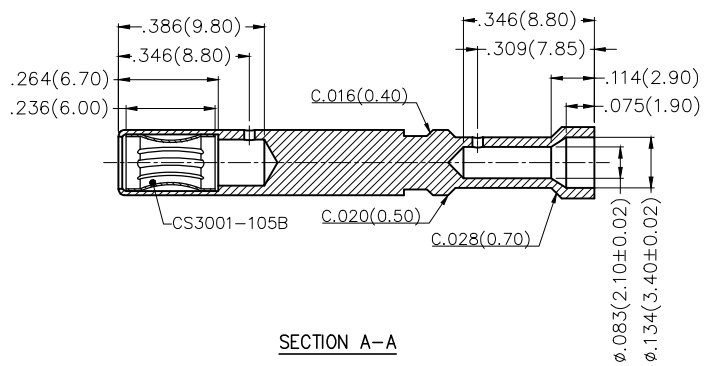
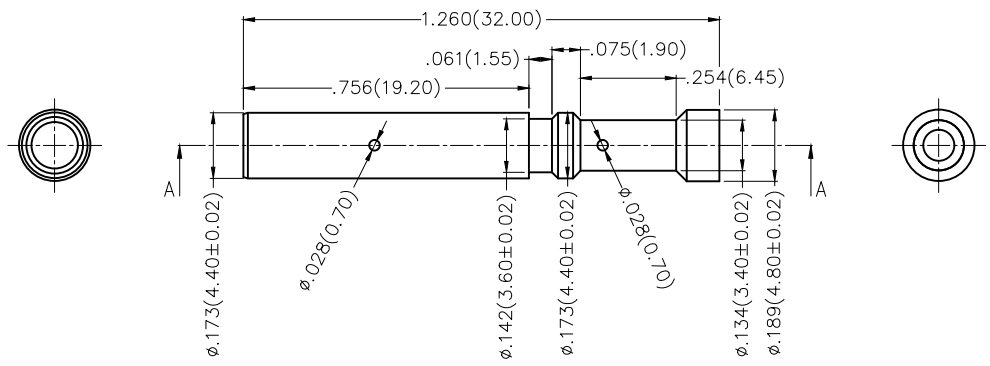

<p>THIRD ANGLE PROJECTION</p>	GENERAL TOLERANCES (UNLESS SPECIFIED)	APPROVE BY FRANK	DATE 28/FEB/17	PART NO. FMT116-F450B	ITEM NO. FMT116	<p>Leader Of Industry</p>	
	±.002(0.05)	CHECKED BY CHERRY	DATE 28/FEB/17	TITLE MACHINED TERMINAL FEMALE			REV 0
	DESIGN UNITS Inch (metric)	±2'	DRAWN BY KATE	DATE 28/FEB/17	THIS DRAWING CONTAINS INFORMATION THAT IS PROPRIETARY TO TXGA INDUSTRIAL ELECTRONICS(S,Z)CO.,LTD AND SHOULD NOT BE USED WITHOUT WRITTEN PERMISSION		

1 2 3 4 5 6 7 8