

1 2 3 4 5 6 7 8

REV	LOCATIONS	DESCRIPTION	DATE	REVISER	APPD

- Notes:
- Material:
 - Machined Terminal: Brass
 - Crown Spring: Beryllium Copper
 - Plating:
 - Machined Terminal: 50µ" Silver Plated, 80~100µ" Nickel Under Plated Over All.
 - Crown Spring: 5µ" Gold Plated, 100~120µ" Nickel Under Plated Over All.
 - Applicable Terminal: $\phi 4.00\text{mm}$
 - Curing test
 - All Materials Meet The "RoHs"
 - 1000 pcs/Bag

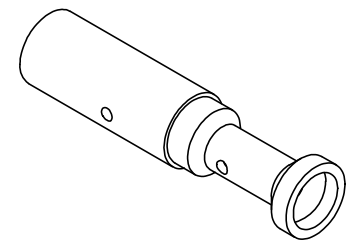
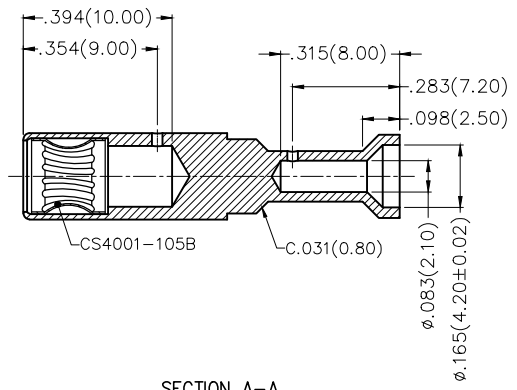
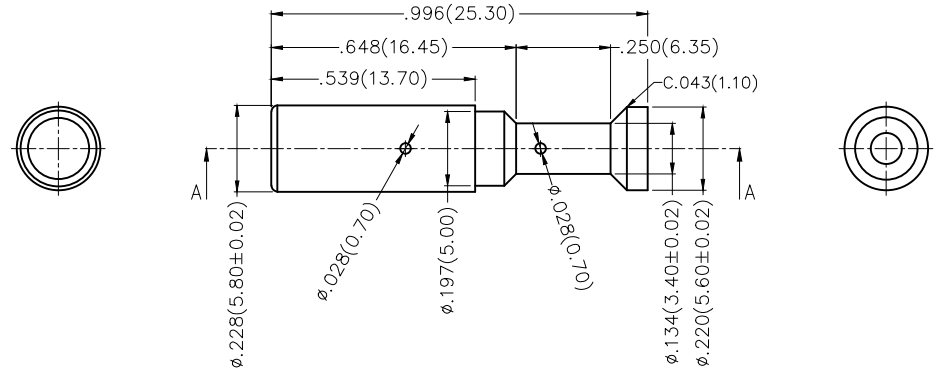

SECTION A-A

<p>THIRD ANGLE PROJECTION</p>	GENERAL TOLERANCES (UNLESS SPECIFIED)	APPROVE BY FRANK	DATE 28/FEB/17	PART NO. FMT119-F450B	ITEM NO. FMT119	<p>Leader Of Industry</p>
	$\pm .002(0.05)$	CHECKED BY CHERRY	DATE 28/FEB/17	TITLE MACHINED TERMINAL FEMALE		
DESIGN UNITS Inch (metric)	$\pm 2'$	DRAWN BY KATE	DATE 28/FEB/17	THIS DRAWING CONTAINS INFORMATION THAT IS PROPRIETARY TO TXGA INDUSTRIAL ELECTRONICS(S,Z)CO.,LTD AND SHOULD NOT BE USED WITHOUT WRITTEN PERMISSION		
SCALE 5:1		SIZE A4			REV 0	SHEET NO. 1/1

1 2 3 4 5 6 7 8