

1 2 3 4 5 6 7 8

REV	LOCATIONS	DESCRIPTION	DATE	REVISER	APPD

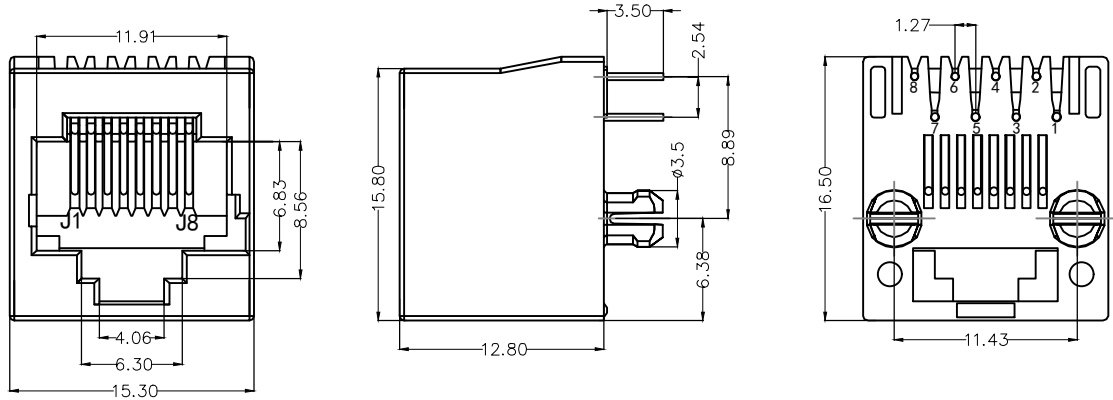

SPECIFICATIONS
Electrical
 Current Rating: 1.5A AC(rms)/DC
 Voltage Rating: 125V AC(rms)/DC
 Contact Resistance: 30 mΩ Max
 Insulation Resistance: 500 MΩ Min
 Withstanding Voltage: 1000V AC r.m.s
 Operating Temperature: -40°C~+85°C
 Durability: 750 Cycles Min.
 Mating Force: 2.2N MAX.
 Retention Strength: 7.7N MAX
 (BETWEEN JACK AND PLUG)

Material and plating
 Housing: PBT (UL 94V-0), Black
 Contacts: Phosphor Bronze/ Gold plated

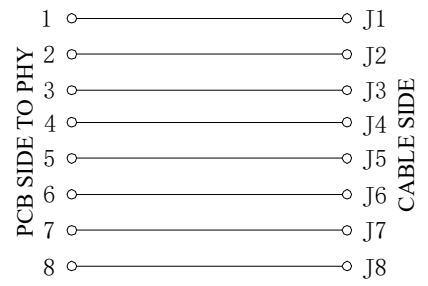
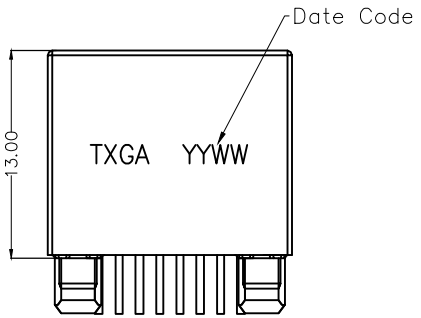

Ordering Information

FRJ45 236 — 1 1 XX BK K 0 2 0 0
 1 2 3 4 5 6 7 8

1 Category FRJ45-RJ45 Connector	2 Distinction No. 236	3 Ports options 1-1 Port	4 Plating 1-Gold plated
5 Thickness of plating 00-Gold flash 03-3μ" Custom plate available	6 Color-Resin BK-Black	7 Packaging K-Tray	8 Contact type 2-Round pin

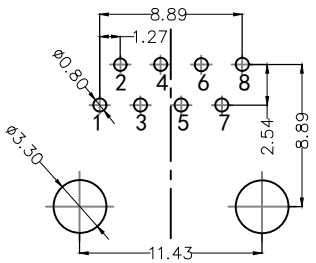

Recommended P.C.Board Layout
 General tolerances ±0.05mm

 THIRD ANGLE PROJECTION	GENERAL TOLERANCES (UNLESS SPECIFIED)		APPROVE BY LEO	DATE 09/OCT/24	PART NO. FRJ45236-11XXBKK0200	ITEM NO. FRJ45236	 Building Technology Cornerstone
	X. ±0.35	X.* ±3'	CHECKED BY GISELLE	DATE 09/OCT/24	TITLE RJ45 Connector 8P8C 180° Vertical DIP		
	DESIGN UNITS METRIC(mm)	X.X ±0.30	X.X' ±2'	DRAWN BY NICK	DATE 09/OCT/24	THIS DRAWING CONTAINS INFORMATION THAT IS PROPRIETARY TO TXGA INDUSTRIAL ELECTRONICS(S,Z)CO.,LTD AND SHOULD NOT BE USED WITHOUT WRITTEN PERMISSION	

1 2 3 4 5 6 7 8