

1 2 3 4 5 6 7 8

REV	LOCATIONS	DESCRIPTION	DATE	REVISER	APPD
1	△	MOQ: Change 10,000 into 20,000 pcs/reel	07/SEP/18	KATE	FRANK

Electrical
 Material: Phosphor Bronze C5191
 Plating: Tin-Plated
 Wire Range: 32AWG~28AWG
 Applicable Housing: FHG12503 Series
 Minimum Order Quantity : 20,000 pcs

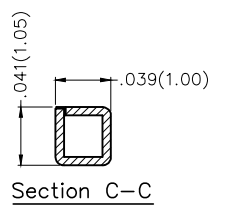
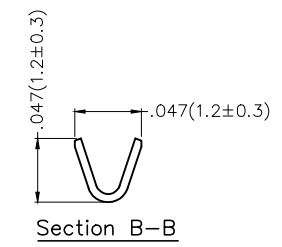
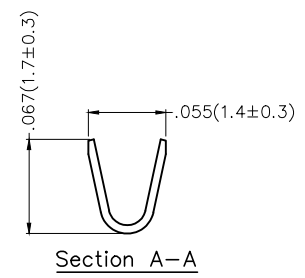
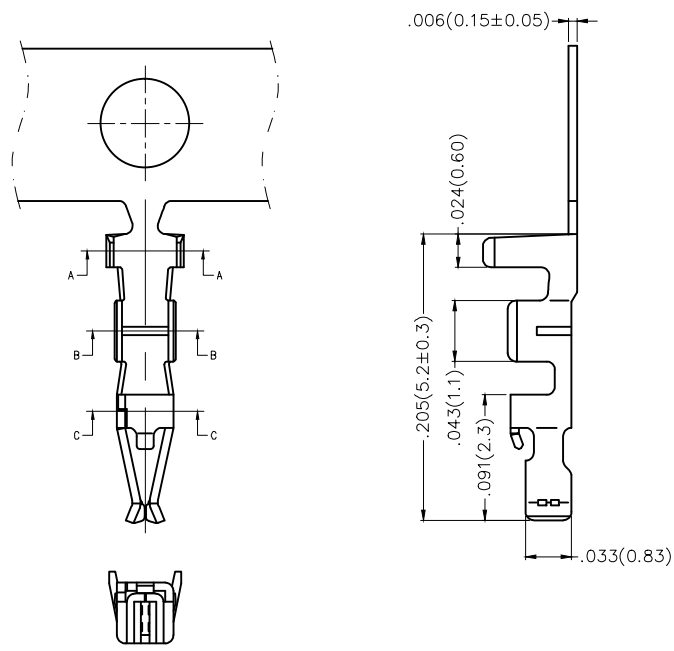

 THIRD ANGLE PROJECTION	GENERAL TOLERANCES (UNLESS SPECIFIED)		APPROVE BY	DATE	PART NO.	ITEM NO.	 Leader Of Industry
	X.±.012(0.30)	X'±5'	FRANK	25/JUN/13	FT12502-F2H	FT12502	
	X.X±.008(0.20)	.X'±2'	CHECKED BY	DATE	TITLE		
	X.XX±.006(0.15)	.XX'±1'	JACOB	25/JUN/13	Wire to Board Pitch 1.25mm(Terminal)		
SCALE	SIZE	X.XXX±.004(0.10)	.XXX'±0.5'	DRAWN BY	DATE	THIS DRAWING CONTAINS INFORMATION THAT IS PROPRIETARY TO TXGA INDUSTRIAL ELECTRONICS(S.Z)CO.,LTD AND SHOULD NOT BE USED WITHOUT WRITTEN PERMISSION	
5:1	A4			CHERRY	25/JUN/13	REV 1	SHEET NO. 1/2

1 2 3 4 5 6 7 8

A
B
C
D
E
F

F
E
C
D
E
F

REV	LOCATIONS	DESCRIPTION	DATE	REVISER	APPD

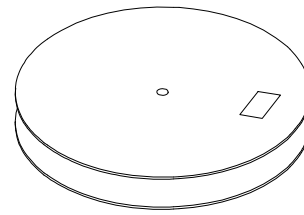
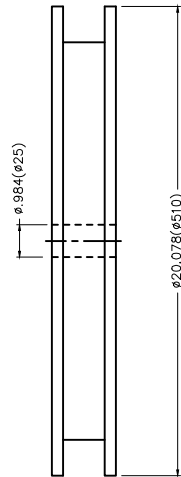
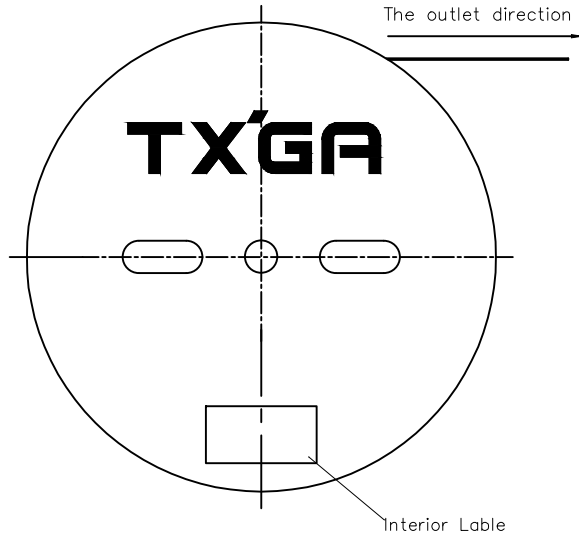

20,000 pcs/Reel

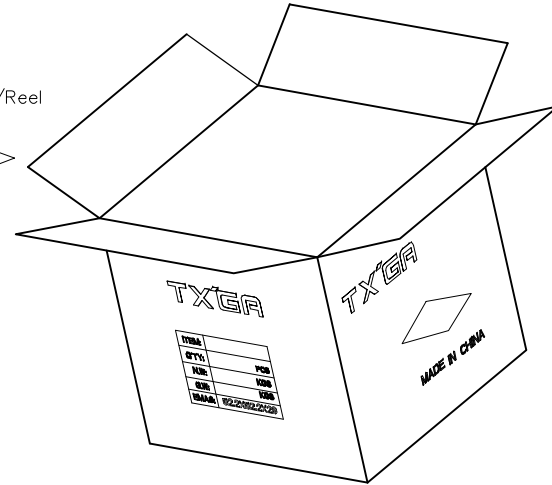

 THIRD ANGLE PROJECTION	GENERAL TOLERANCES (UNLESS SPECIFIED)		APPROVE BY FRANK	DATE 25/JUN/13	PART NO. FT12502-F2H	ITEM NO. FT12502	 Leader Of Industry		
	DESIGN UNITS Inch (metric)	X.±.012(0.30) X.X±.008(0.20)	X.'±5' .X'±2'	CHECKED BY JACOB	DATE 25/JUN/13	TITLE Wire to Board Pitch 1.25mm(Terminal)		REV 1	SHEET NO. 2/2
	SCALE 5:1	SIZE A4	X.XX±.006(0.15) X.XXX±.004(0.10)	.XX'±1' .XXX'±0.5'	DRAWN BY CHERRY	DATE 25/JUN/13	THIS DRAWING CONTAINS INFORMATION THAT IS PROPRIETARY TO TXGA INDUSTRIAL ELECTRONICS(S.Z)CO.,LTD AND SHOULD NOT BE USED WITHOUT WRITTEN PERMISSION		