

1 2 3 4 5 6 7 8

REV	LOCATIONS	DESCRIPTION	DATE	REVISER	APPD
1	△	MOQ: Change 4,000 into 4,500 pcs/reel	09/AUG/18	KATE	FRANK

Notes:

1. Material: Phosphor Bronze C5191
2. Plating: Tin-Plated
3. Wire Range: 16AWG~24AWG
4. Insulation O.D. 106(ø2.70mm Max)
5. Applicable Housing: FHG45003Series
6. Minimum Order Quantity 4,500 PCS

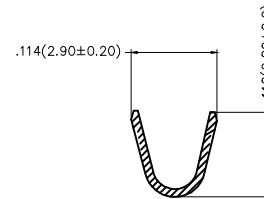
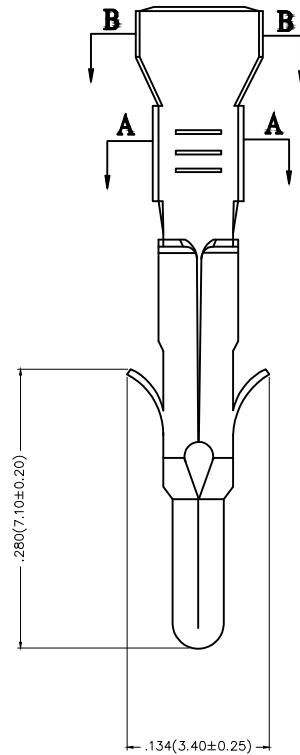
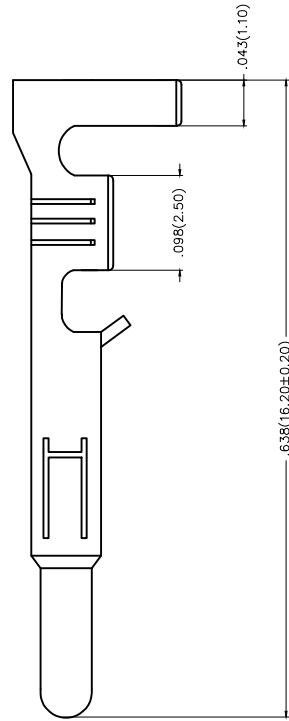

A-A

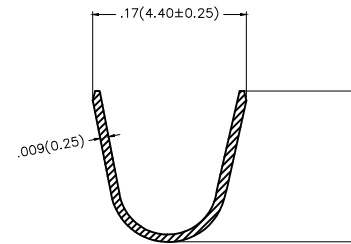

B-B

 THIRD ANGLE PROJECTION	GENERAL TOLERANCES (UNLESS SPECIFIED)		APPROVE BY FRANK	DATE 18/AUG/15	PART NO. FT45003-M2H	ITEM NO. FT45003	 Leader Of Industry
	DESIGN UNITS Inch (metric)	X.±.012(0.30)	X'±5'	CHECKED BY CHERRY	DATE 18/AUG/15	TITLE Wire to Board Pitch 4.5mm(Terminal)	
SCALE 5:1	SIZE A4	X.XX±.006(0.15)	.XX'±1'	DRAWN BY KEVIN	DATE 18/AUG/15	THIS DRAWING CONTAINS INFORMATION THAT IS PROPRIETARY TO TXGA INDUSTRIAL ELECTRONICS(S.Z)CO.,LTD AND SHOULD NOT BE USED WITHOUT WRITTEN PERMISSION	
		X.XXX±.004(0.10)	.XXX'±0.5'			REV 1	SHEET NO. 1/2

1 2 3 4 5 6 7 8

A  
B  
C  
D  
E  
F

A  
B  
C  
D  
E  
F

REV	LOCATIONS	DESCRIPTION	DATE	REVISER	APPD

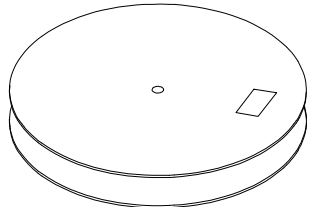
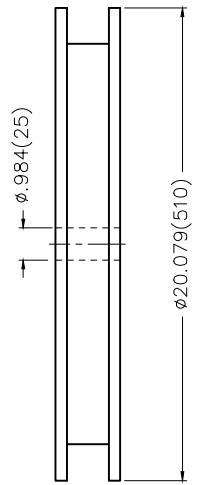
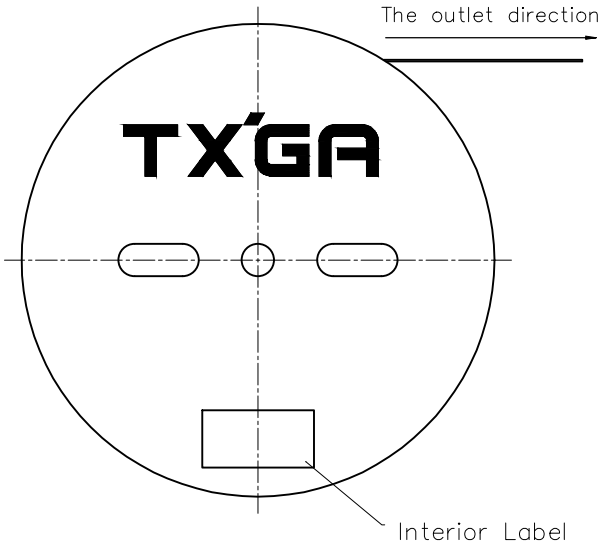

4,500 Pcs/Reel

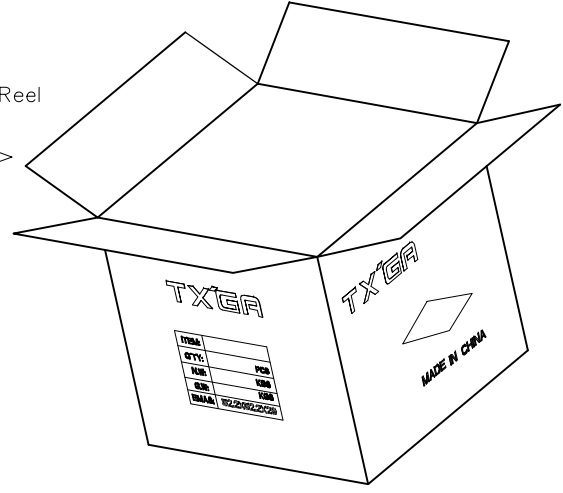

 THIRD ANGLE PROJECTION	GENERAL TOLERANCES (UNLESS SPECIFIED)		APPROVE BY FRANK	DATE 18/AUG/15	PART NO. FT45003-M2H	ITEM NO. FT45003	 Leader Of Industry
	DESIGN UNITS Inch (metric)	X.±.012(0.30)	X.±5'	CHECKED BY CHERRY	DATE 18/AUG/15	TITLE Wire to Board Pitch 4.5mm(Terminal)	
SCALE 5:1	SIZE A4	X.XX±.006(0.15)	.XX'±1'	DRAWN BY CHERRY	DATE 18/AUG/15	THIS DRAWING CONTAINS INFORMATION THAT IS PROPRIETARY TO TXGA INDUSTRIAL ELECTRONICS(S.Z)CO.,LTD AND SHOULD NOT BE USED WITHOUT WRITTEN PERMISSION	
		X.XXX±.004(0.10)	.XXX'±0.5'			REV 1	SHEET NO. 2/2