

REV	LOCATIONS	DESCRIPTION	DATE	REVISER	APPD

SPECIFICATIONS

Electrical

Current Rating: 3.0A AC(rms)/DC
Voltage Rating: 5V AC(rms)/DC
Contact Resistance: 40mΩ Max
Insulation Resistance: 100MΩ Min
Withstanding Voltage: 100V AC r.m.s

Mechanical

Mating force: 0.5–2.0KG.F
Retention force: 0.8–2.0KG.F
Durability: 10000 cycles Min.

Environmental

Operating Temperature: -25°C~+85°C

Material and plating

Housing: LCP (UL 94V-0), Black
Contacts: Copper Alloy/Gold plated on contact, Matte Tin plated on tail
Shell: Stainless steel/Nikel plated
IP Rating: IPX7

Circuits	A	Circuits	B
A1	GND	B12	GND
A2	/	B11	/
A3	/	B10	/
A4	VBUS	B9	VBUS
A5	CC1	B8	SBU2
A6	DP1	B7	DN2
A7	DN1	B6	DP2
A8	SBU1	B5	CC2
A9	VBUS	B4	VBUS
A10	/	B3	/
A11	/	B2	/
A12	GND	B1	GND

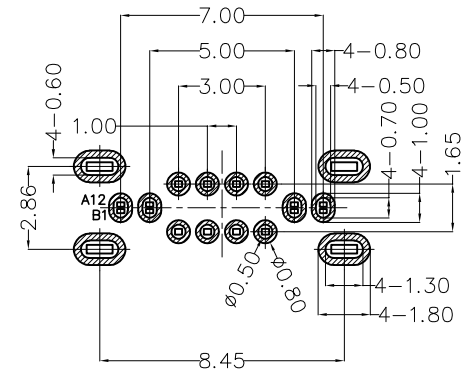

Recommended P.C.Board Layout

General tolerances ±0.05mm

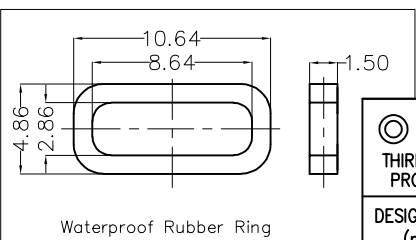
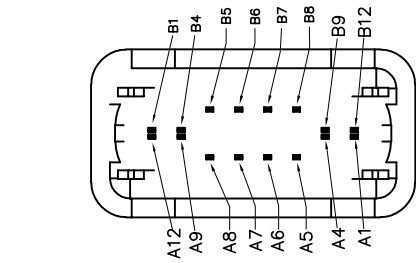
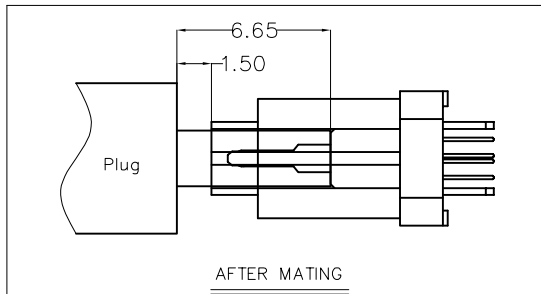
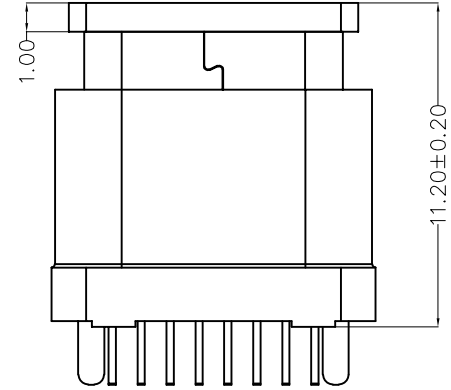
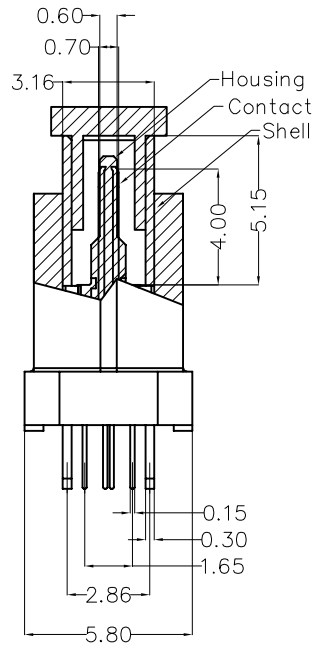
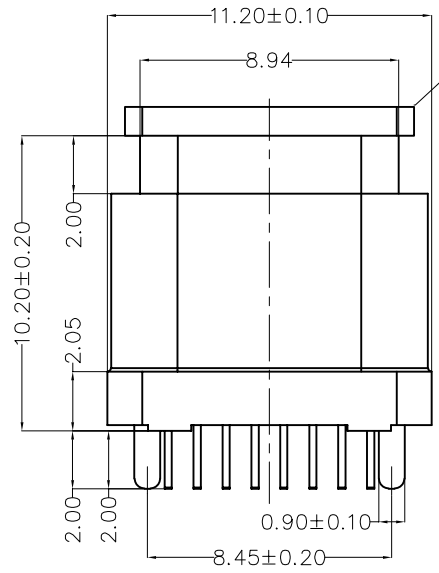
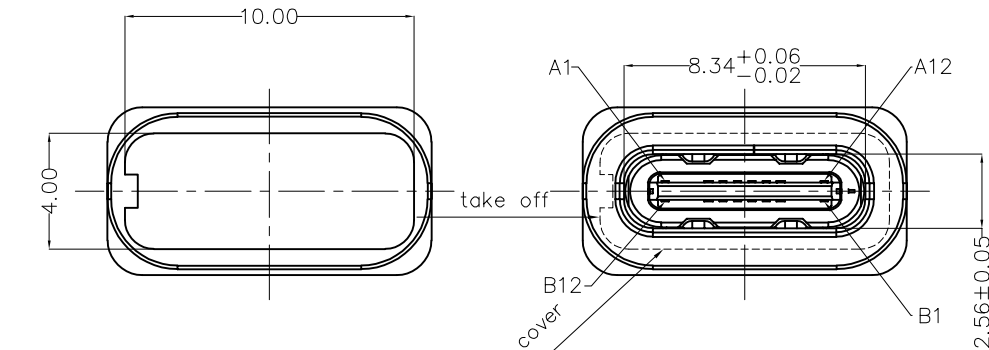

Waterproof Rubber Ring

THIRD ANGLE PROJECTION	
DESIGN UNITS (metric)	SCALE 5:1
SIZE A4	

GENERAL TOLERANCES (UNLESS SPECIFIED)		APPROVE BY FRANK	DATE 26/SEP/22
X.±0.30	X.±5°	CHECKED BY CHERRY	DATE 26/SEP/22
X.XX±0.15	.XX±1°	DRAWN BY QING	DATE 26/SEP/22
X.XXX±0.10	.XXX±0.5°		

PART NO. FUS6101-FDSBKM	ITEM NO. FUS6101
TITLE USB C-type 180°Vertical Female(DIP)(3.1)	

TXGA Leader Of Industry	
REV 0	SHEET NO. 1/2
THIS DRAWING CONTAINS INFORMATION THAT IS PROPRIETARY TO TXGA INDUSTRIAL ELECTRONICS(S.Z)CO.,LTD AND SHOULD NOT BE USED WITHOUT WRITTEN PERMISSION	

REV	LOCATIONS	DESCRIPTION	DATE	REVISER	APPD

- Note:
- 1.10 sprocket hole cumulative tolerance ± 0.2
 2. Carrier camber is within 1.0mm in 250mm
 3. Material: Clear conductive polystyrene Alloy 100% recyclable
 4. All dimensions meet EIA-481-3 requirements
 5. Peel off force of cover tape & carrier tape: 20g~130g (0.2N~1.3N)
 6. Component load per 13" reel: 300 pcs

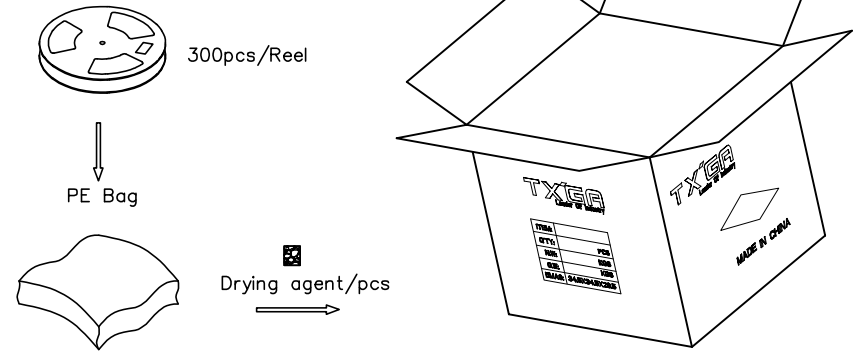
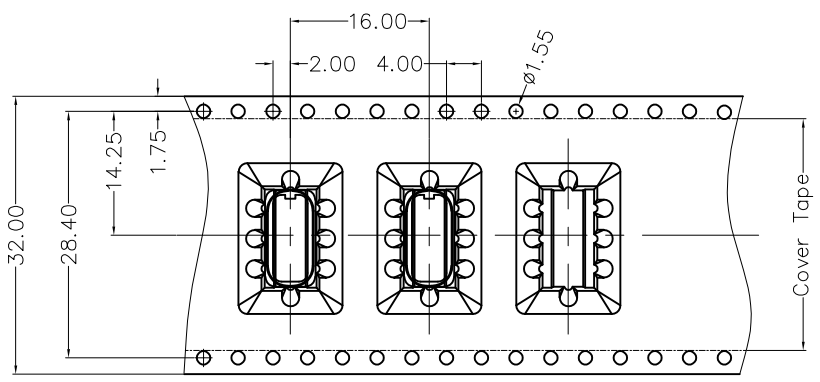
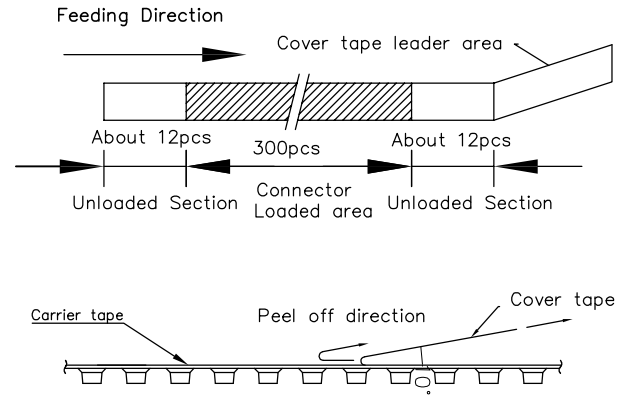
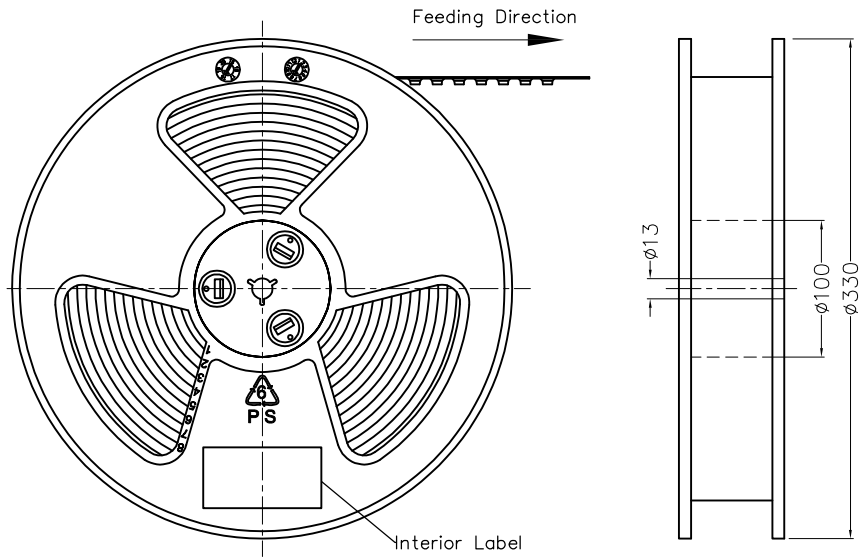

Feeding Direction →

 THIRD ANGLE PROJECTION	GENERAL TOLERANCES (UNLESS SPECIFIED)		APPROVE BY	DATE	PART NO.	ITEM NO.	 Leader Of Industry	
	X.±0.30	X.±5'	FRANK	26/SEP/22	FUS6101-FDSBKM	FUS6101		
	DESIGN UNITS (metric)		CHECKED BY	DATE	TITLE			REV 0
	X.X±0.20	.X'±2'	CHERRY	26/SEP/22	USB C-type 180°Vertical Female(DIP)(3.1)			SHEET NO. 2/2
SCALE	SIZE	X.XX±0.15	.XX'±1"	DRAWN BY	DATE	THIS DRAWING CONTAINS INFORMATION THAT IS PROPRIETARY TO TXGA INDUSTRIAL ELECTRONICS(S.Z)CO.,LTD AND SHOULD NOT BE USED WITHOUT WRITTEN PERMISSION		
5:1	A4	X.XXX±0.10	.XXX'±0.5"	QING	26/SEP/22			