

REV	LOCATIONS	DESCRIPTION	DATE	REVISER	APPD

SPECIFICATIONS

Electrical

Current Rating: 5.0A
Voltage Rating: 5V AC(rms)
Contact Resistance: 40 mΩ Max.
Insulation Resistance: 100 MΩ Min.
Withstanding Voltage: 100V AC r.m.s
Temperature Range-Operating: -40°C~+85°C

Mechanical

Insertion Force: 5~20 N
Withdrawal Force: 8~20 N
Durability: 10,000 cycles

Material and Plating

Housing: PA9T 30%G.F (UL94 V-0), Black
Terminal: Copper alloy/ 3μ" Gold plated on contact area and gold flash on tails area
MID Plate: SUS 301/ Nickel plated
Shell: SUS 304/ Nickel plated

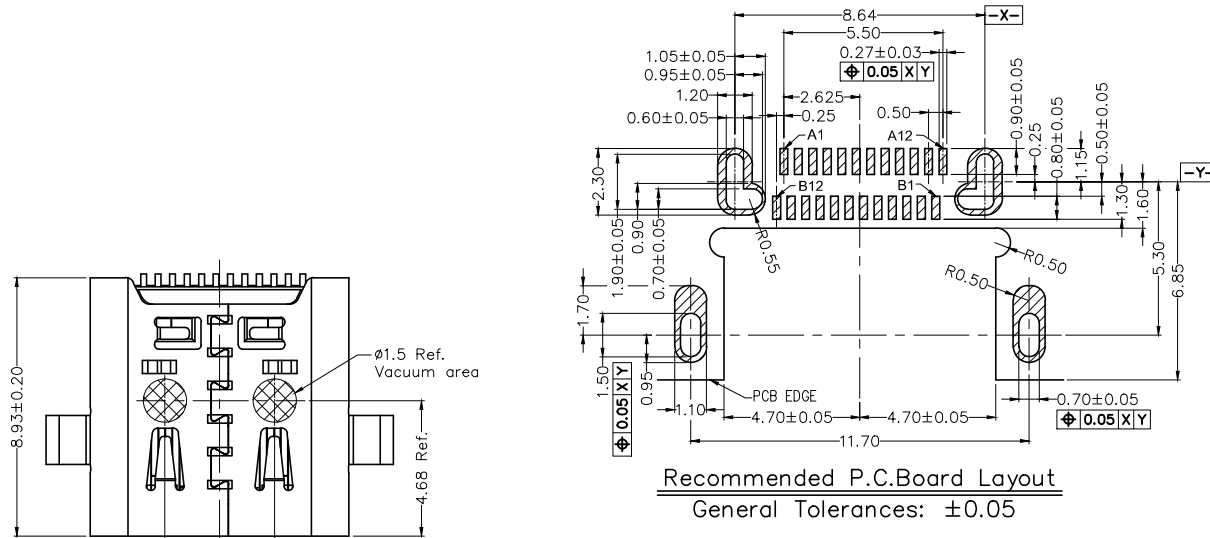

Recommended P.C.Board Layout
General Tolerances: ±0.05

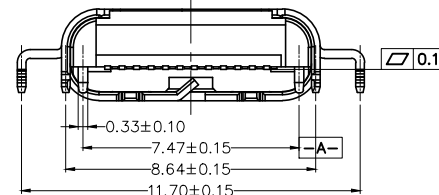
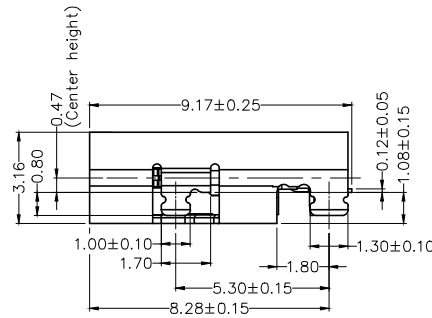
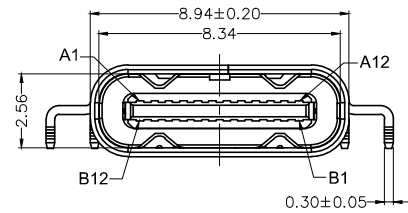

Pin assignment

Circuits	A	Circuits	B
A1	GND	B12	GND
A2	TX1+	B11	RX1+
A3	TX1-	B10	RX1-
A4	VBUS	B9	VBUS
A5	CC1	B8	SBU2
A6	D+	B7	D-
A7	D-	B6	D+
A8	SBU1	B5	CC2
A9	VBUS	B4	VBUS
A10	RX2-	B3	TX2-
A11	RX2+	B2	TX2+
A12	GND	B1	GND

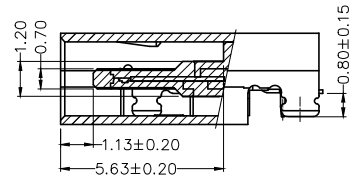
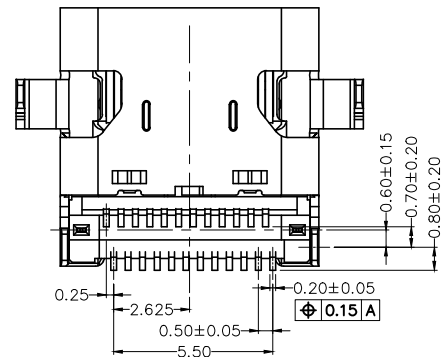

<p>THIRD ANGLE PROJECTION</p>	GENERAL TOLERANCES (UNLESS SPECIFIED)		APPROVE BY	DATE	PART NO.	ITEM NO.	<p>Leader Of Industry</p>
	X. ±0.30	X.* ±5°	FRANK	24/APR/22	FUS643-FSBBKM	FUS643	
	X.X ±0.20	X.X* ±2°	CHECKED BY	DATE	TITLE		
	X.XX ±0.15	X.XX* ±1°	CHERRY	24/APR/22	USB Type C 90° Angle Female(SMT)(3.1)		
SCALE	SIZE	X.XXX ±0.10	X.XXX* ±0.5°	DRAWN BY	DATE	THIS DRAWING CONTAINS INFORMATION THAT IS PROPRIETARY TO TXGA INDUSTRIAL ELECTRONICS(S.Z)CO.,LTD AND SHOULD NOT BE USED WITHOUT WRITTEN PERMISSION	
1:1	A4			KATE	24/APR/22	REV 0	SHEET NO. 1/2

REV	LOCATIONS	DESCRIPTION	DATE	REVISER	APPD

A
B
C
D
E
F

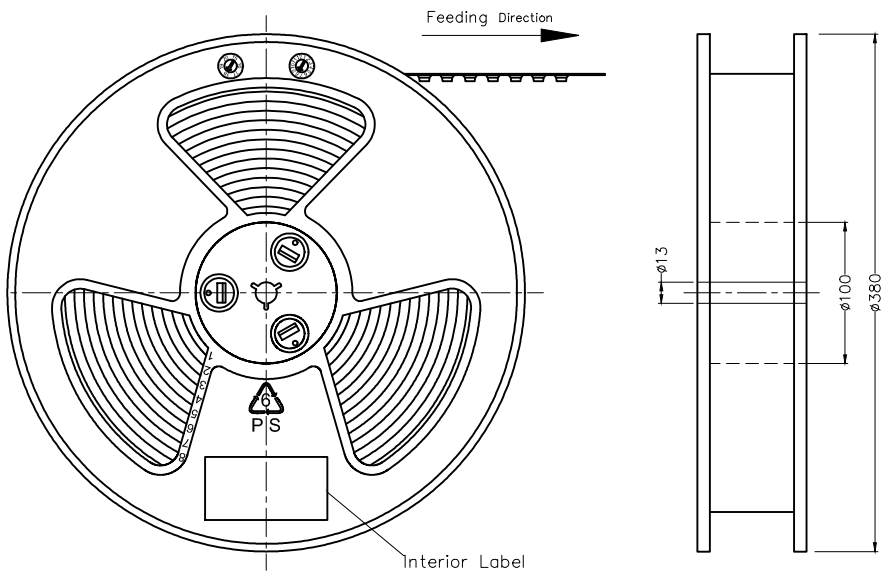

- Note:
- 10 sprocket hole cumulative tolerance±0.2
 - Carrier camber is within 1.0mm in 250mm
 - Material: Clear conductive polystyrene Alloy 100% recyclable
 - All dimensions meet EIA-481-3 requirements
 - Peel off force of cover tape & carrier tape: 20g~130g (0.2N~1.3N)
 - Component load per 15" reel: 1,500 pcs

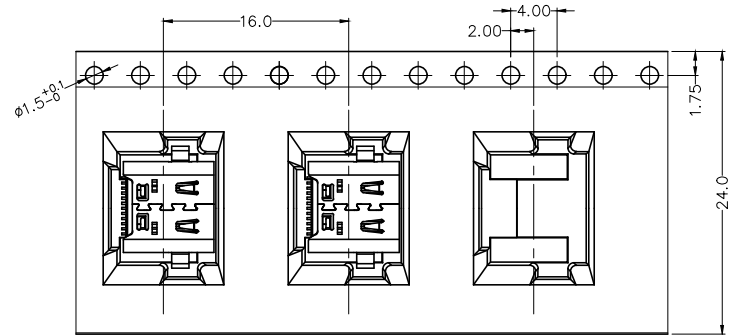
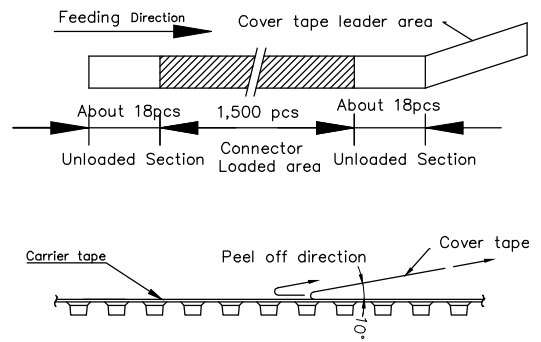

Feeding Direction

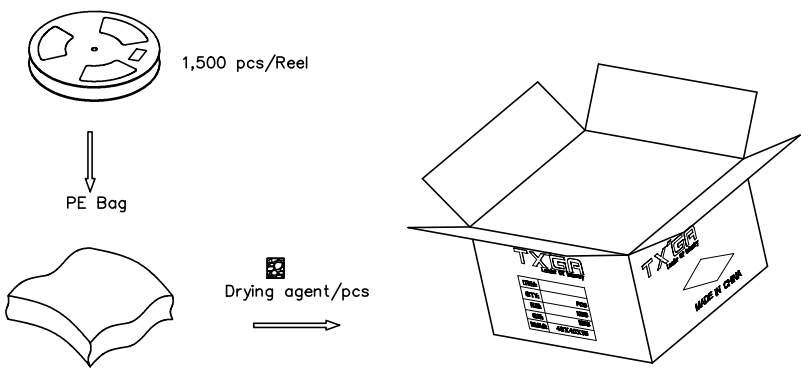
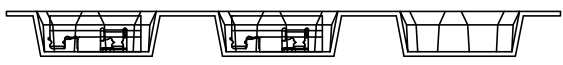

<p>THIRD ANGLE PROJECTION</p>	GENERAL TOLERANCES (UNLESS SPECIFIED)		APPROVE BY	DATE	PART NO.	ITEM NO.	<p>Leader Of Industry</p>
	X. ±0.30	X.* ±5°	FRANK	24/APR/22	FUS643-FSBBKM	FUS643	
	X.X ±0.20	X.X* ±2°	CHECKED BY	DATE	TITLE		
	X.XX ±0.15	X.XX* ±1°	CHERRY	24/APR/22	USB Type C 90° Angle Female(SMT)(3.1)		
SCALE	SIZE	X.XXX ±0.10	X.XXX* ±0.5°	DRAWN BY	DATE	THIS DRAWING CONTAINS INFORMATION THAT IS PROPRIETARY TO TXGA INDUSTRIAL ELECTRONICS(S.Z)CO.,LTD AND SHOULD NOT BE USED WITHOUT WRITTEN PERMISSION	
1:1	A4			KATE	24/APR/22	REV 0	SHEET NO. 2/2