

REV	LOCATIONS	DESCRIPTION	DATE	REVISER	APPD

A
B
C
D
E
F

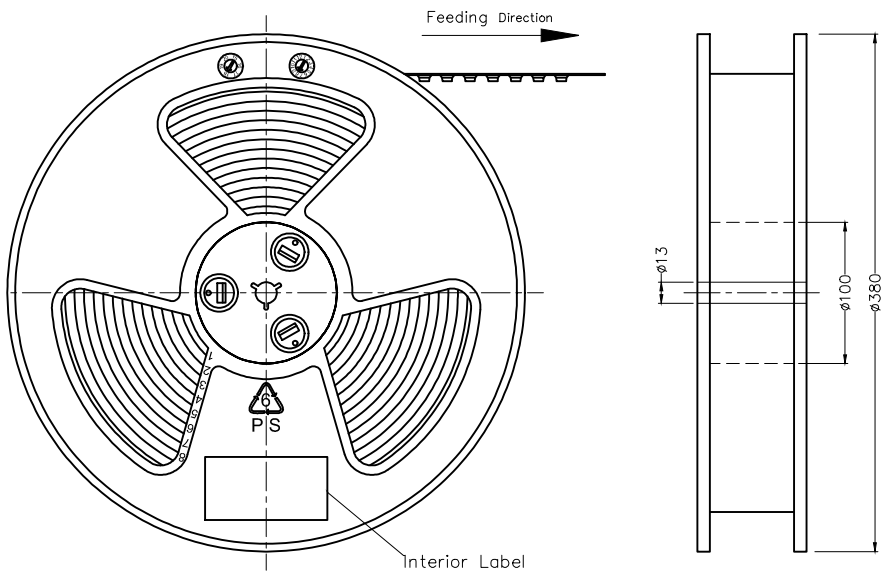

- Note:
1. 10 sprocket hole cumulative tolerance±0.2
 2. Carrier camber is within 1.0mm in 250mm
 3. Material: Clear conductive polystyrene Alloy 100% recyclable
 4. All dimensions meet EIA-481-3 requirements
 5. Peel off force of cover tape & carrier tape: 20g~130g (0.2N~1.3N)
 6. Component load per 15" reel: 1,100 pcs

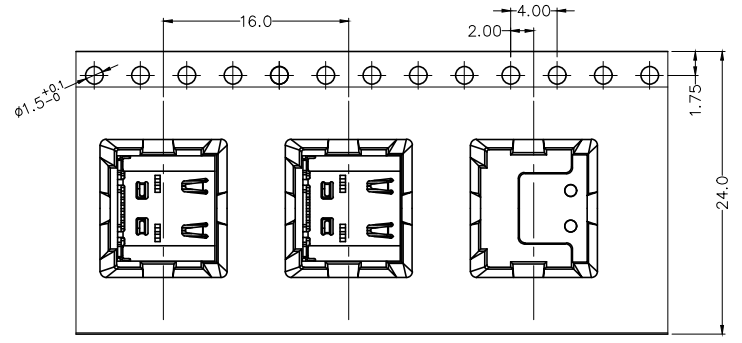
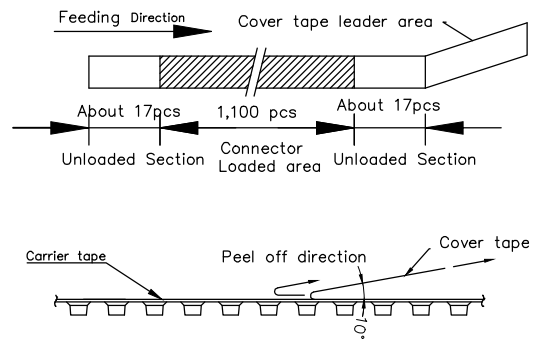

Feeding Direction →

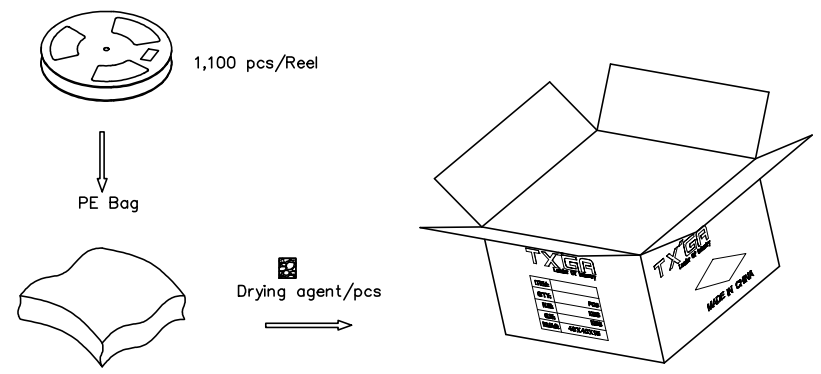
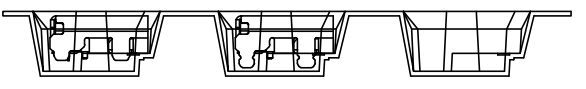

<p>THIRD ANGLE PROJECTION</p>	GENERAL TOLERANCES (UNLESS SPECIFIED)		APPROVE BY	DATE	PART NO.	ITEM NO.	<p>Leader Of Industry</p>
	X. ±0.30	X.* ±5°	FRANK	25/APR/22	FUS646-FSBBKM	FUS646	
	X.X ±0.20	X.X* ±2°	CHECKED BY	DATE	TITLE		
	X.XX ±0.15	X.XX* ±1°	CHERRY	25/APR/22	USB Type C 90° Angle Female(SMT)(3.1)		
SCALE	SIZE	X.XXX ±0.10	X.XXX* ±0.5°	DRAWN BY	DATE	THIS DRAWING CONTAINS INFORMATION THAT IS PROPRIETARY TO TXGA INDUSTRIAL ELECTRONICS(S.Z)CO.,LTD AND SHOULD NOT BE USED WITHOUT WRITTEN PERMISSION	
1:1	A4			KATE	25/APR/22	REV 0	SHEET NO. 2/2