

REV	LOCATIONS	DESCRIPTION	DATE	REVISER	APPD

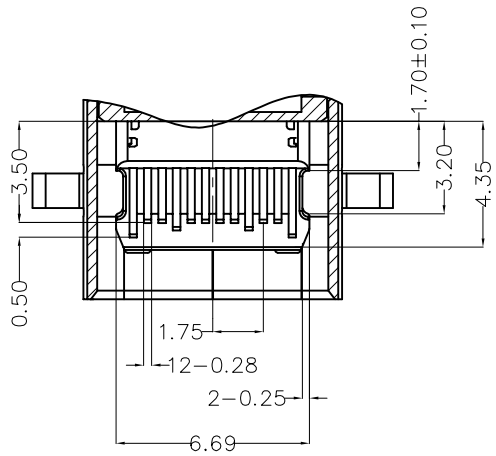
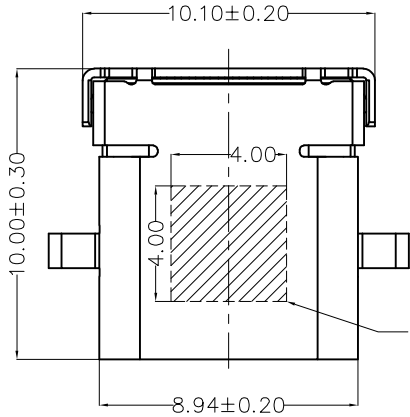

Section B-B

SPECIFICATIONS

Electrical
 Current Rating: 5.0A AC(rms)/DC
 Voltage Rating: 20V AC(rms)/DC
 Contact Resistance: 40mΩ Max
 Insulation Resistance: 100MΩ Min
 Withstanding Voltage: 100V AC r.m.s

Mechanical
 Mating force: 0.5–2.0KG.F
 Retention force: 0.8–2.0KG.F
 Durability: 10000 cycles Min.

Environmental
 Operating Temperature: -30°C~+80°C

Material and plating
 Housing: LCP (UL 94V-0), Black
 Contacts: Copper Alloy/Gold plated
 Shell: Stainless steel/Nikel plated

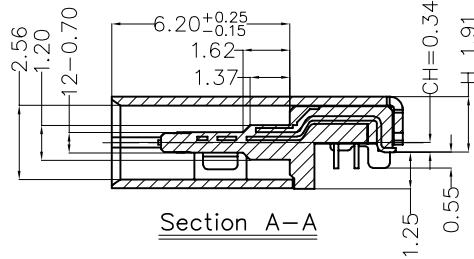
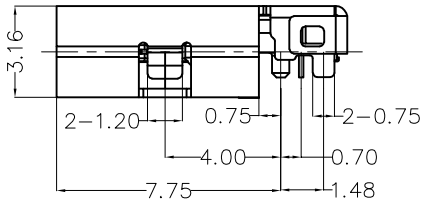
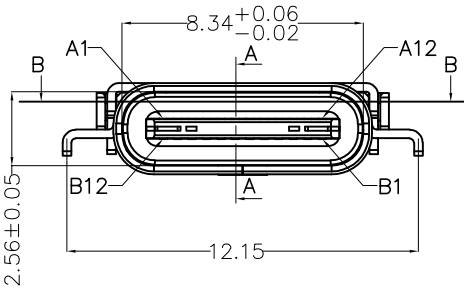

Section A-A

Circuits	A	Circuits	B
A1	GND	B12	GND
A2	SSTXp1	B11	SSRXp1
A3	SSTXn1	B10	SSRXn1
A4	VBUS	B9	VBUS
A5	CC1	B8	SBU2
A6	DP1	B7	DN2
A7	DN1	B6	DP2
A8	SBU1	B5	CC2
A9	VBUS	B4	VBUS
A10	SSRXn2	B3	SSTXn2
A11	SSRXp2	B2	SSTXp2
A12	GND	B1	GND

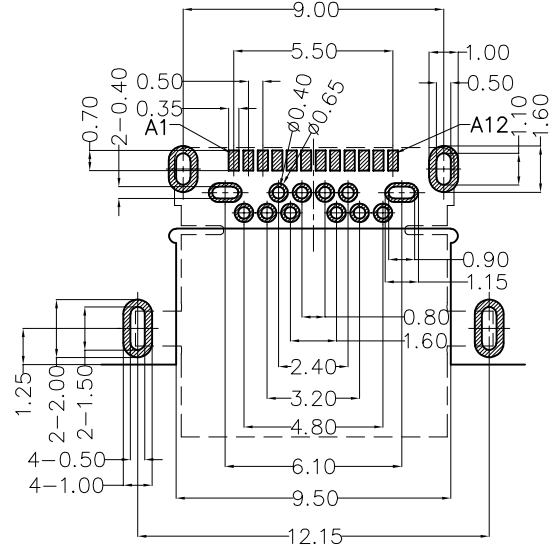

Recommended P.C.Board Layout
 General tolerances ±0.05mm

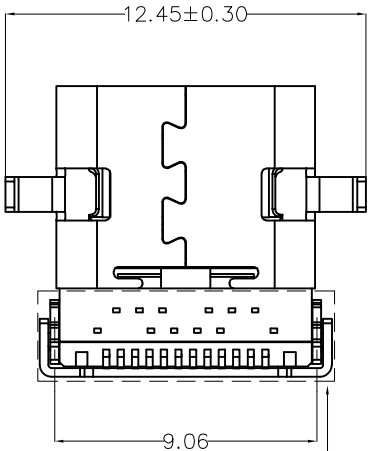

Detail A

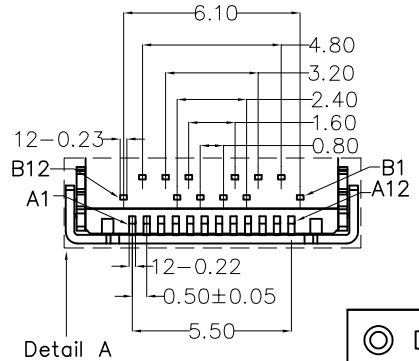

 THIRD ANGLE PROJECTION	
DESIGN UNITS (metric)	SCALE 5:1
SIZE A4	

GENERAL TOLERANCES (UNLESS SPECIFIED)		APPROVE BY FRANK	DATE 13/SEP/22
X.±0.30	X.±5°	CHECKED BY CHERRY	DATE 13/SEP/22
X.XX±0.15	.XX'±1°	DRAWN BY QING	DATE 13/SEP/22
X.XXX±0.10	.XXX'±0.5°		

PART NO. FUS648-FSBBKM	ITEM NO. FUS648
TITLE USB C-type 90° Angle Female(Hybrid solder)	
THIS DRAWING CONTAINS INFORMATION THAT IS PROPRIETARY TO TXGA INDUSTRIAL ELECTRONICS(S,Z)CO.,LTD AND SHOULD NOT BE USED WITHOUT WRITTEN PERMISSION	

TXGA
 Leader Of Industry

REV 0 SHEET NO. 1/2

REV	LOCATIONS	DESCRIPTION	DATE	REVISER	APPD

- Note:
- 1.10 sprocket hole cumulative tolerance ± 0.2
 2. Carrier camber is within 1.0mm in 250mm
 3. Material: Clear conductive polystyrene Alloy 100% recyclable
 4. All dimensions meet EIA-481-3 requirements
 5. Peel off force of cover tape & carrier tape: 20g~130g (0.2N~1.3N)
 6. Component load per 13" reel: 1000 pcs

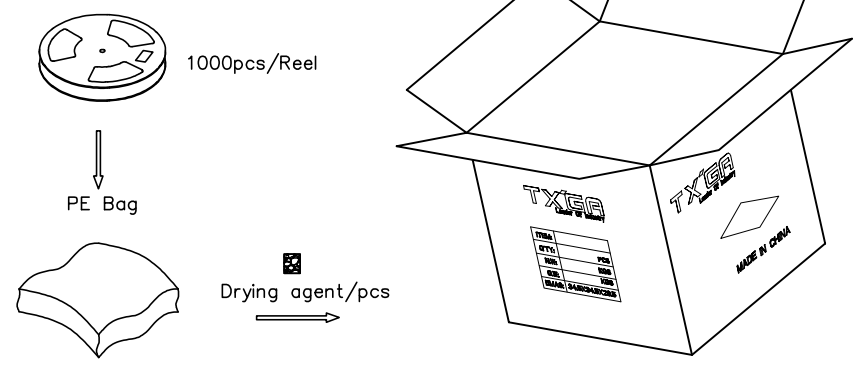
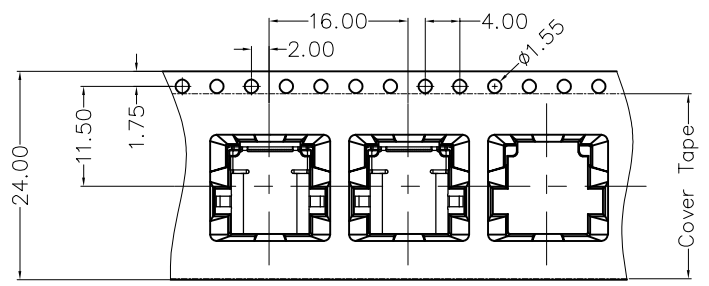
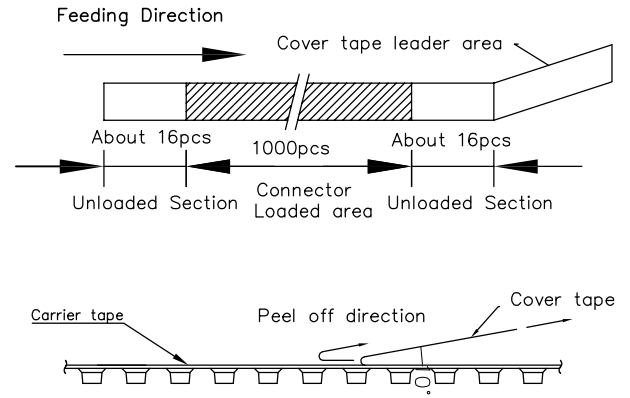
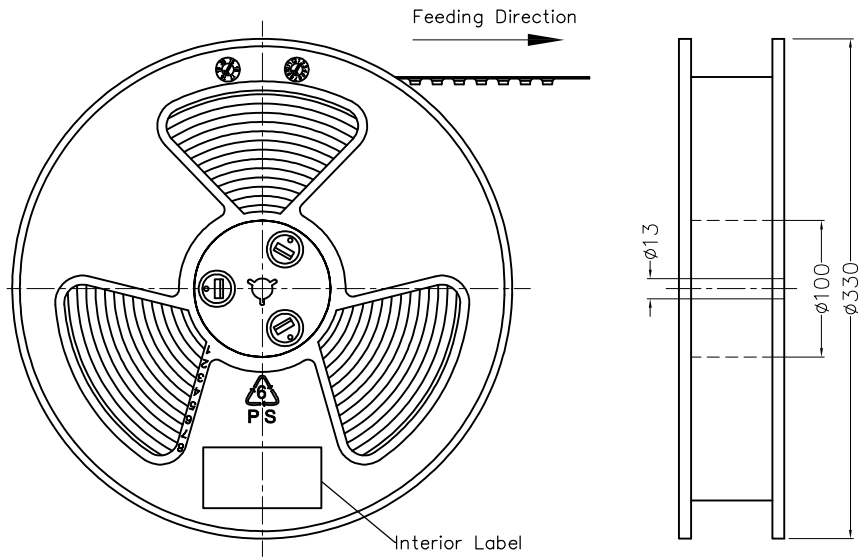

Feeding Direction

 THIRD ANGLE PROJECTION	GENERAL TOLERANCES (UNLESS SPECIFIED)		APPROVE BY FRANK	DATE 13/SEP/22	PART NO. FUS648-FSBBKM	ITEM NO. FUS648	 Leader Of Industry	
	X.±0.30	X.±5'	CHECKED BY CHERRY	DATE 13/SEP/22	TITLE USB C-type 90° Angle Female(Hybrid solder)			
DESIGN UNITS (metric)	X.X±0.20	.X'±2'	DRAWN BY QING	DATE 13/SEP/22	THIS DRAWING CONTAINS INFORMATION THAT IS PROPRIETARY TO TXGA INDUSTRIAL ELECTRONICS(S.Z)CO.,LTD AND SHOULD NOT BE USED WITHOUT WRITTEN PERMISSION		REV 0	SHEET NO. 2/2
SCALE 5:1	SIZE A4	X.XX±0.15	.XX'±1"					
		X.XXX±0.10	.XXX'±0.5"					