

REV	LOCATIONS	DESCRIPTION	DATE	REVISER	APPD

SPECIFICATIONS

Electrical
 Current Rating: 3.0A AC(rms)/DC
 Voltage Rating: 5.0V AC(rms)/DC
 Contact Resistance: 50 mΩ Max
 Insulation Resistance: 100 MΩ Min
 Withstanding Voltage: 100V AC r.m.s
 Operating Temperature: -25°C~+85°C

Mechanical
 Durability: 5000 cycles Min.
 Mating force: 0.5-2.0KG.F
 Retention force: 0.8-2.0KG.F

Material and plating
 Housing: LCP (UL 94V-0), Black
 Contacts: Copper Alloy/Gold Plated
 Shell: Stainless steel/Nickel Plated

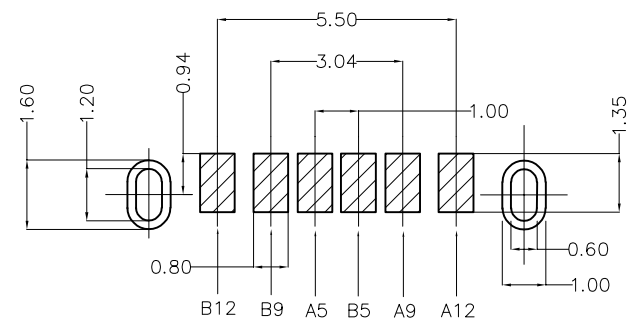
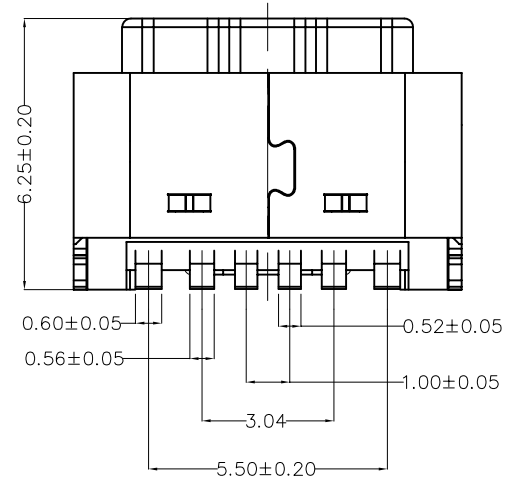
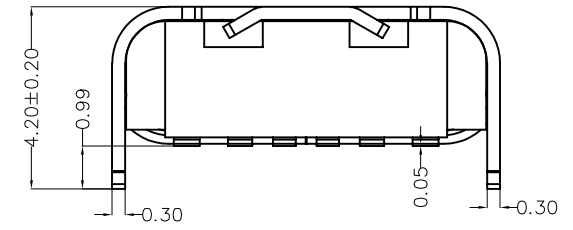
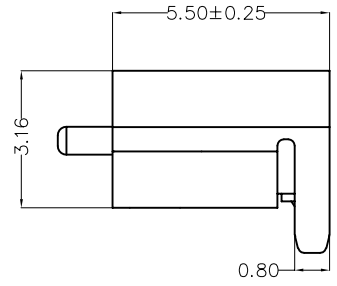
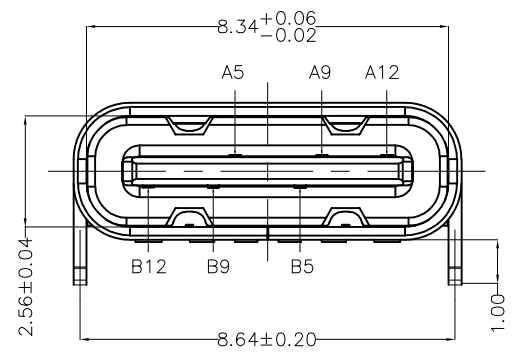
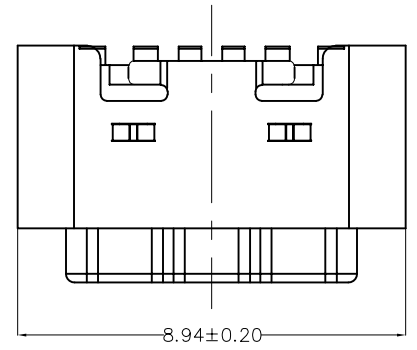

Recommended P.C.Board Layout
 General tolerances ±0.05mm

Circuits	A
A5	CC1
A9	VBUS
A12	GND
Circuits	B
B5	CC2
B9	VBUS
B12	GND

 THIRD ANGLE PROJECTION	GENERAL TOLERANCES (UNLESS SPECIFIED)		APPROVE BY FRANK	DATE 13/JUL/22	PART NO. FUS665-FSBBKM	ITEM NO. FUS665	 Leader Of Industry
	X.±0.30	X.±5°	CHECKED BY CHERRY	DATE 13/JUL/22	TITLE USB C-type 90° Angle Female(SMT)(3.1)		
DESIGN UNITS (metric)	X.X±0.20	.X'±2'	DRAWN BY QING	DATE 13/JUL/22	THIS DRAWING CONTAINS INFORMATION THAT IS PROPRIETARY TO TXGA INDUSTRIAL ELECTRONICS(S.Z)CO.,LTD AND SHOULD NOT BE USED WITHOUT WRITTEN PERMISSION		REV 0
SCALE 5:1	SIZE A4	X.XX±0.15					SHEET NO. 1/2
		X.XXX±0.10					

REV	LOCATIONS	DESCRIPTION	DATE	REVISER	APPD

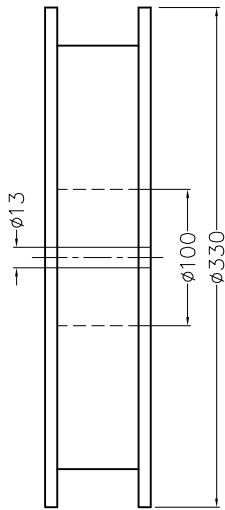
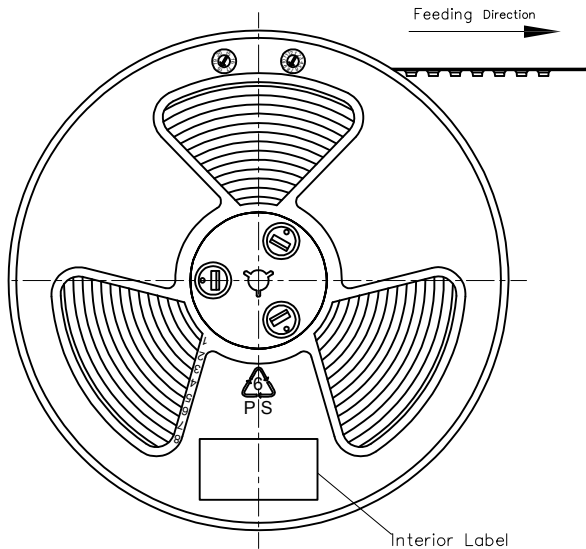

- Note:
- 1.10 sprocket hole cumulative tolerance ± 0.2
 2. Carrier camber is within 1.0mm in 250mm
 3. Material: Clear conductive polystyrene Alloy 100% recyclable
 4. All dimensions meet EIA-481-3 requirements
 5. Peel off force of cover tape & carrier tape: 20g~130g (0.2N~1.3N)
 6. Component load per 13" reel: 1000 pcs

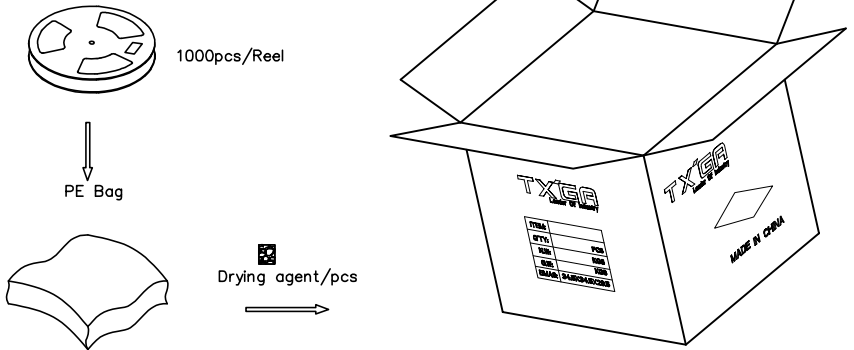
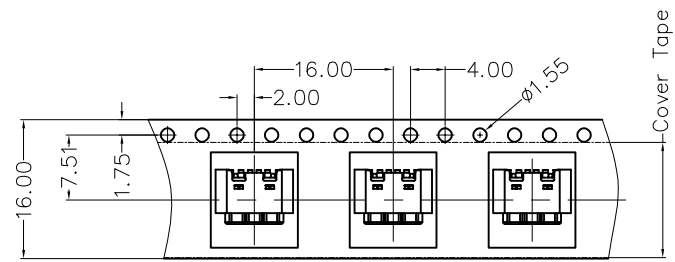
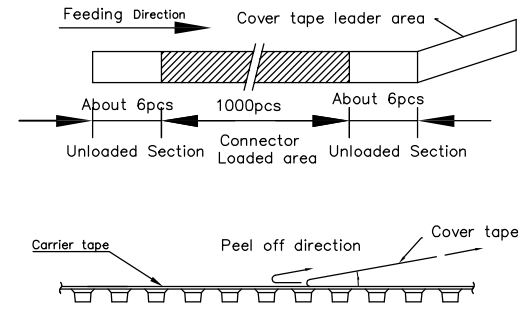

 THIRD ANGLE PROJECTION	GENERAL TOLERANCES (UNLESS SPECIFIED)		APPROVE BY FRANK	DATE 13/JUL/22	PART NO. FUS665-FSBBKM	ITEM NO. FUS665	 Leader Of Industry
	X.±0.30	X.±5'	CHECKED BY CHERRY	DATE 13/JUL/22	TITLE USB C-type 90° Angle Female(SMT)(3.1)		
DESIGN UNITS (metric)	X.X±0.20	.X'±2'	DRAWN BY QING	DATE 13/JUL/22	THIS DRAWING CONTAINS INFORMATION THAT IS PROPRIETARY TO TXGA INDUSTRIAL ELECTRONICS(S.Z)CO.,LTD AND SHOULD NOT BE USED WITHOUT WRITTEN PERMISSION		
SCALE 5:1	SIZE A4	X.XX±0.15	.XX'±1"				
		X.XXX±0.10	.XXX'±0.5"				