

REV	LOCATIONS	DESCRIPTION	DATE	REVISER	APPD

**SPECIFICATIONS**

**Electrical**  
 Current Rating: 5.0A AC(rms)/DC  
 Voltage Rating: 20V AC(rms)/DC  
 Contact Resistance: 40mΩ Max  
 Insulation Resistance: 100MΩ Min  
 Withstanding Voltage: 100V AC r.m.s

**Mechanical**  
 Mating force: 0.5–2.0KG.F  
 Retention force: 0.8–2.0KG.F  
 Durability: 10000 cycles Min.

**Environmental**  
 Operating Temperature: -30°C~+80°C

**Material and plating**  
 Housing: LCP (UL 94V-0), Black  
 Contacts: Copper Alloy/Gold plated  
 Shell: Stainless steel/Nikel plated

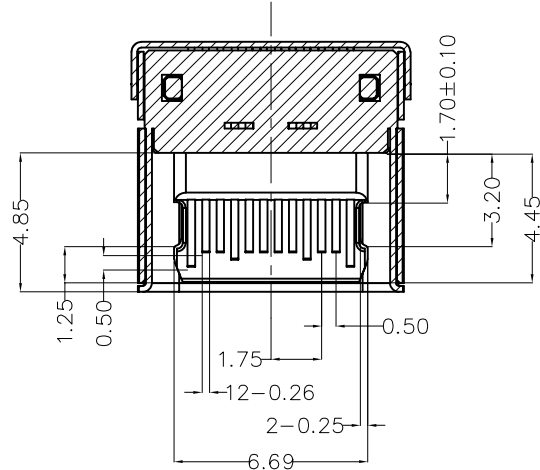

**Section B-B**

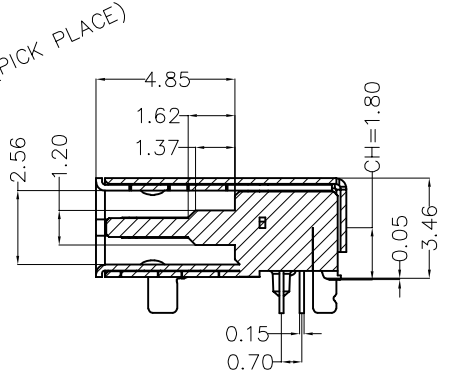

**Section A-A**

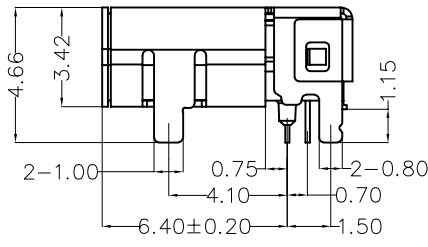
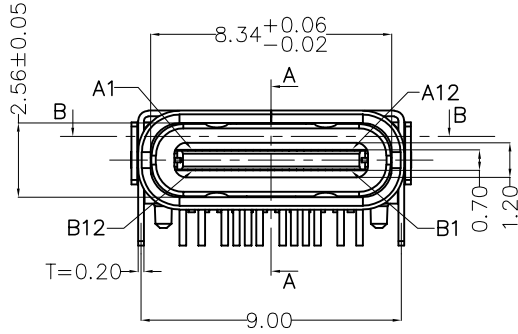
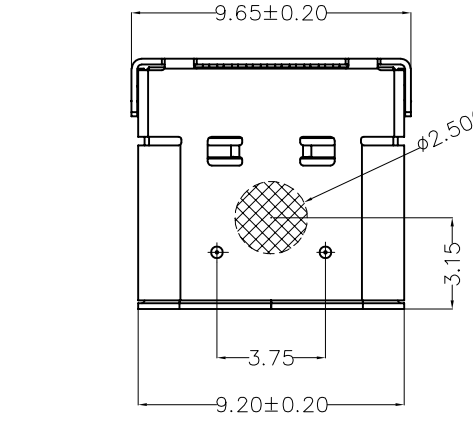

Circuits	A	Circuits	B
A1	GND	B12	GND
A2	SSTXp1	B11	SSRXp1
A3	SSTXn1	B10	SSRXn1
A4	VBUS	B9	VBUS
A5	CC1	B8	SBU2
A6	DP1	B7	DN2
A7	DN1	B6	DP2
A8	SBU1	B5	CC2
A9	VBUS	B4	VBUS
A10	SSRXn2	B3	SSTXn2
A11	SSRXp2	B2	SSTXp2
A12	GND	B1	GND

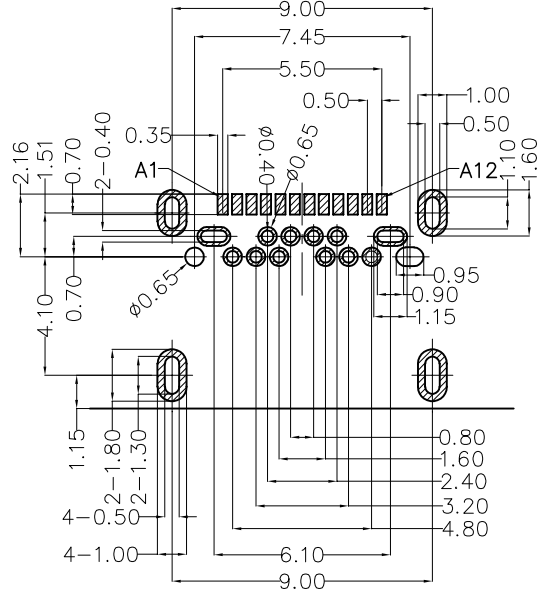

**Recommended P.C.Board Layout**  
 General tolerances ±0.05mm

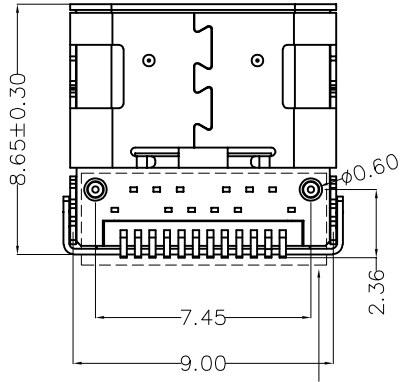

**Detail A**

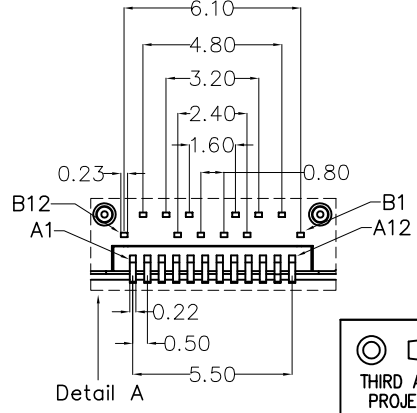

**Detail A**

 THIRD ANGLE PROJECTION	GENERAL TOLERANCES (UNLESS SPECIFIED)		APPROVE BY	DATE	PART NO.	ITEM NO.	 Leader Of Industry	
	X.±0.30	X'±5'	FRANK	13/SEP/22				FUS689-FSBBKM
DESIGN UNITS (metric)		CHECKED BY	DATE	TITLE		REV 0		SHEET NO. 1/2
X.X±0.20	.X'±2'	CHERRY	13/SEP/22	USB C-type				
SCALE	SIZE	DRAWN BY	DATE	THIS DRAWING CONTAINS INFORMATION THAT IS PROPRIETARY TO TXGA INDUSTRIAL ELECTRONICS(S.Z)CO.,LTD AND SHOULD NOT BE USED WITHOUT WRITTEN PERMISSION				
5:1	A4	QING	13/SEP/22					

1 2 3 4 5 6 7 8

REV	LOCATIONS	DESCRIPTION	DATE	REVISER	APPD

A  
B  
C  
D  
E  
F

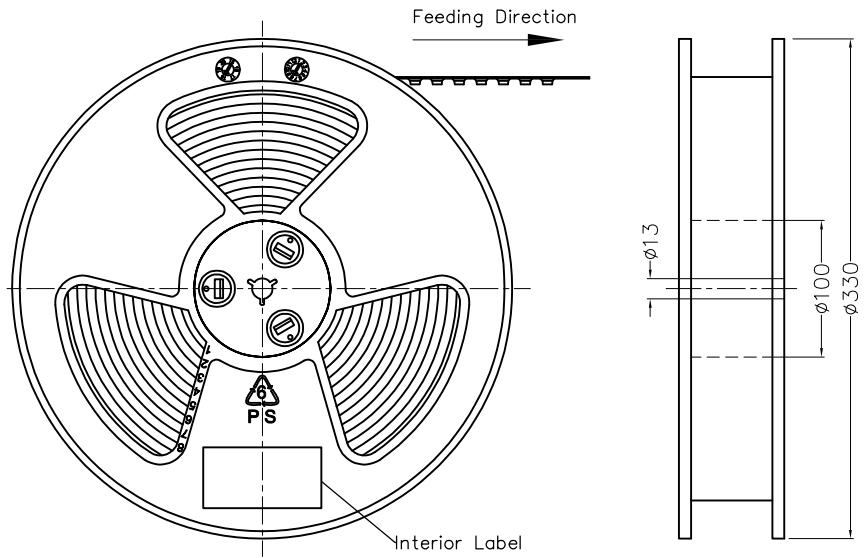

- Note:
- 1.10 sprocket hole cumulative tolerance  $\pm 0.2$
  2. Carrier camber is within 1.0mm in 250mm
  3. Material: Clear conductive polystyrene Alloy 100% recyclable
  4. All dimensions meet EIA-481-3 requirements
  5. Peel off force of cover tape & carrier tape: 20g~130g (0.2N~1.3N)
  6. Component load per 13" reel: 800 pcs

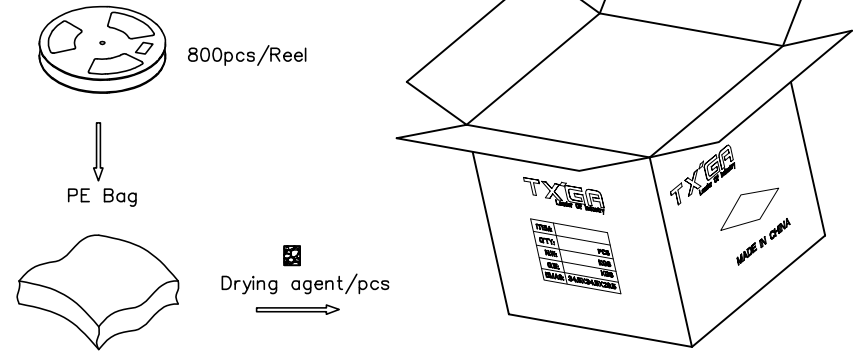
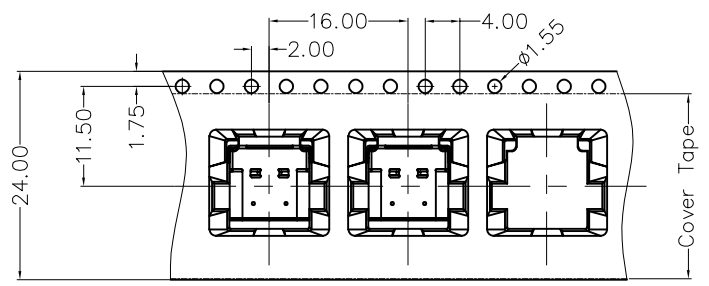
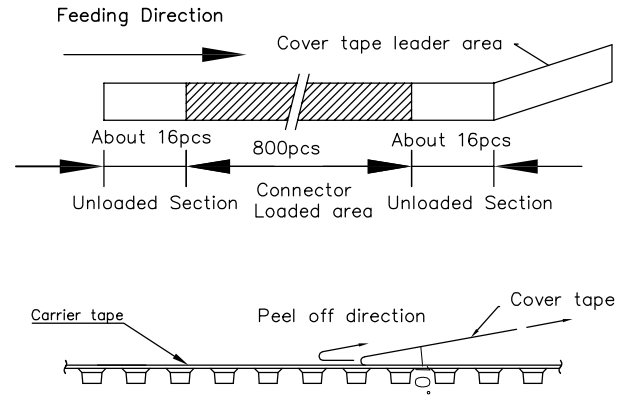

 THIRD ANGLE PROJECTION	GENERAL TOLERANCES (UNLESS SPECIFIED)		APPROVE BY FRANK	DATE 13/SEP/22	PART NO. FUS689-FSBBKM	ITEM NO. FUS689	 Leader Of Industry
	DESIGN UNITS (metric)	X.±0.30	X.±5'	CHECKED BY CHERRY	DATE 13/SEP/22	TITLE USB C-type 90° Angle Female(Hybrid solder)	
SCALE 5:1	SIZE A4	X.XX±0.15	.XX'±1"	DRAWN BY QING	DATE 13/SEP/22	THIS DRAWING CONTAINS INFORMATION THAT IS PROPRIETARY TO TXGA INDUSTRIAL ELECTRONICS(S.Z)CO.,LTD AND SHOULD NOT BE USED WITHOUT WRITTEN PERMISSION	
		X.XXX±0.10	.XXX'±0.5"			REV 0	SHEET NO. 2/2

1 2 3 4 5 6 7 8