

| WIRING CHART |       |          |
|--------------|-------|----------|
| P1           | COLOR | P2 Label |
| 1            | White | 1        |
| 2            | White | 2        |
| 3            | White | 3        |
| •            | •     | •        |
| •            | •     | •        |
| •            | •     | •        |
| 67           | White | 67       |
| 68           | White | 68       |
| 69           | White | 69       |

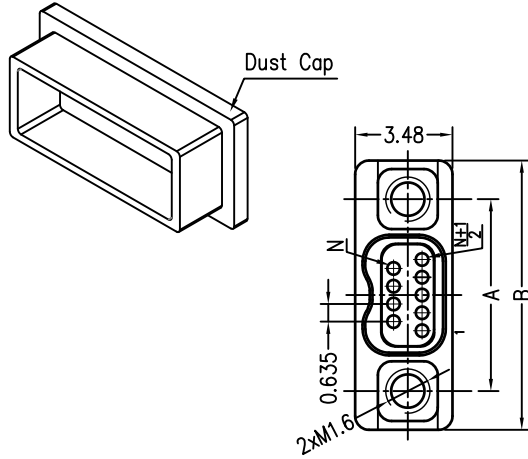

Specifications

Electrical

- Current Rating: 1A
- Voltage Rating: 250V AC(rms)
- Contact Resistance: 21mΩ (MAX)
- Insulation Resistance: 5000MΩ (MIN)
- Temperature Range-Operating: -55°C~+125°C

Mechanical

- Durability: 200 Cycles
- Vibration: Frequency 10~2000Hz, Acceleration 196m/s<sup>2</sup>,
- Shock: Peak Acceleration 980m/s<sup>2</sup> 6ms.

Material and Plating

- Shell: Aluminum alloy /plated Nickel
- Terminal: Copper alloy /plated Gold
- Wire: AFR250 0.035mm<sup>2</sup> White

Table 1:

| Circuits (n) | Part No.           | Dimensions(mm) |       |
|--------------|--------------------|----------------|-------|
|              |                    | A              | B     |
| 9            | FWND0-S009XXXX-001 | 6.86           | 9.63  |
| 15           | FWND0-S015XXXX-001 | 8.76           | 11.53 |
| 21           | FWND0-S021XXXX-001 | 10.67          | 13.44 |
| 25           | FWND0-S025XXXX-001 | 11.94          | 14.71 |
| 31           | FWND0-S031XXXX-001 | 13.84          | 16.61 |
| 37           | FWND0-S037XXXX-001 | 15.75          | 18.52 |
| 51           | FWND0-S051XXXX-001 | 20.19          | 22.96 |
| 65           | FWND0-S065XXXX-001 | 24.64          | 27.41 |
| 69           | FWND0-S069XXXX-001 | 25.91          | 28.68 |

| REV | LOCATIONS | DESCRIPTION            | DATE       | REVISER | APPD  |
|-----|-----------|------------------------|------------|---------|-------|
| 1   | △         | ADD LENGTH EXPLANATION | 2025-09-09 |         | HUANG |

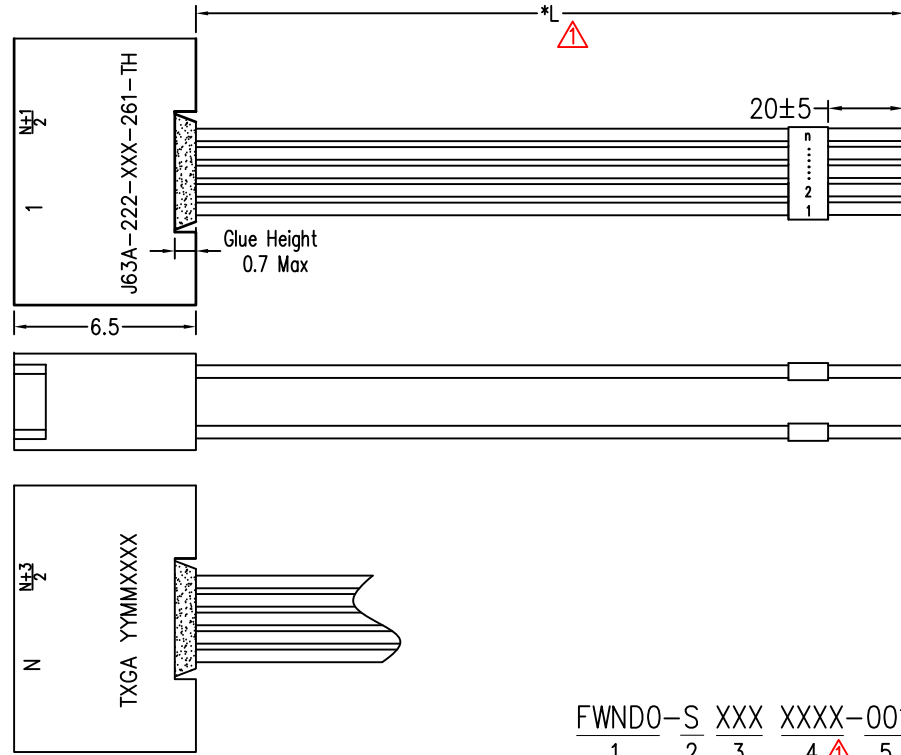

FWND0-S XXX XXXX-001  
1 2 3 4 △ 5

| 1 | Category               | 2 | Type                 | 3 | Circuits                 | 4 | Length △         | 5 | Standard Parts |
|---|------------------------|---|----------------------|---|--------------------------|---|------------------|---|----------------|
| 1 | FWND0-Nano D connector | 2 | S-One-way plug cable | 3 | 009-9P<br>015-15P<br>... | 4 | XXXX-See Table 2 | 5 | 001            |

| Table 2:<br>△ | LENGTH EXPLANATION (mm) |                                    |       |       |                                       |       |  |        |   |       |        |
|---------------|-------------------------|------------------------------------|-------|-------|---------------------------------------|-------|--|--------|---|-------|--------|
|               | Wire length (xxxx)      | 0100                               | 0150  | 0200  | 0310                                  | 0500  | 0800                                   | 1000   | 1200                                    | ..... | 1500   |
|               |                         | 100mm                              | 150mm | 200mm | 310mm                                 | 500mm | 800mm                                  | 1000mm | 1200mm                                  | ..... | 1500mm |
|               | Tolerance               | 0~300 <sup>+15</sup> <sub>-5</sub> |       |       | 301~500 <sup>+30</sup> <sub>-10</sub> |       | 501~1000 <sup>+50</sup> <sub>-10</sub> |        | 1001~1500 <sup>+80</sup> <sub>-10</sub> |       |        |

|                               |                                       |              |            |            |  |  |  |  |
|-------------------------------|---------------------------------------|--------------|------------|------------|--|--|--|--|
| <p>THIRD ANGLE PROJECTION</p> | GENERAL TOLERANCES (UNLESS SPECIFIED) |              | APPROVE BY | DATE       | PART NO.   | ITEM NO.                                   | <p>Building Technology Cornerstone</p> |  |
|                               | X. ±0.30                              | X.* ±5°      | LEO        | 06/MAR/25  | FWND0-SXXXXXXX-001   | FWND0                                      |  |  |
|                               | DESIGN UNITS mm                       | X.X ±0.20    | X.X' ±2°   | CHECKED BY | DATE   | TITLE                                      |  |  |
|                               | SCALE NTS                             | X.XX ±0.15   | X.XX' ±1°  | GISELLE    | 06/MAR/25  | Nano D connector Female One-way plug cable |  |  |
| SIZE A4                       | X.XXX ±0.10                           | X.XXX' ±0.5° | DRAWN BY   | DATE       | THIS DRAWING CONTAINS INFORMATION THAT IS PROPRIETARY TO TXGA INDUSTRIAL ELECTRONICS(S.Z)CO.,LTD AND SHOULD NOT BE USED WITHOUT WRITTEN PERMISSION |  |  |  |
|                               |                                       |              | HUANG      | 06/MAR/25  | REV 1 SHEET NO. 1/1  |  |  |  |